

2505

2019-0010

()

0	1
0.1	1
0.2	2
0.3	2
0.4	3
0.5	3
0.6	4
1	5
1.1	5
1.2	7
1.3	8
1.4	8
1.5	9
1.6	10
1.7	15
1.8	20
2	24
2.1	24
2.2	24
2.3	26
2.4	26
2.5	26
2.6	28
2.7	28
2.8	32
2.9	35
2.10	36
2.11	38
2.12	38
3	39
3.1	39

3.2	45
3.3	48
3.4	50
3.5	67
3.6	67
4	75
4.1	75
4.2	79
4.3	79
5	80
5.1	80
5.2	82
5.3	86
5.4	89
5.5	91
5.6	93
6	97
6.1	97
6.2	97
6.3	99
6.4	101
6.5	101
7	104
7.1	104
7.2	116
7.3	117
7.4	122
7.5	124
8	126
8.1	126
8.2	126
8.3	128

8.4	131
8.5	133
8.6	133
8.7	135
8.8	136
8.9	136
9	137
9.1	137
9.2	139
9.3	143
9.4	148
9.5	150
9.6	151
9.7	153
9.8	153
9.9	153
10	156
10.1	156
10.2	161
11	165
11.1	165
11.2	165
11.3	165
11.4	166
11.5	166
12	167
12.1	167
12.2	167
12.3	168
12.4	168
12.5	169
13	171

13.1	171
13.2	176
14	179
14.1	179
14.2	179
14.3	179
14.4	179
14.5	179
14.6	181
14.7	181
14.8	182
14.9	183

1.

2.

[2019]12

3.

[2007]574

0

0.1

2020

20%

2016 6

30

20

50%

506111

128.4hm²(1926)

10

2017

10 1

44

<

>

1

2015

0.2

2019 3 5

2019 3

2019 3

0.3

0.4

0.4.1

2011

2013

2009

2012-2020

2017 1055

[2016]114

0.4.2

0.6

1

GB/T18075.1-2012

1

1.1

1.1.1

1.1.1.1 2015 1 1

1.1.1.2 2017 10 1

1.1.1.3 2018 12 29

1.1.1.4 2018 10 26

1.1.1.5 2018 1 1

1.1.1.6 1997 3 1

1.1.1.7 2016 11 7

1.1.1.8 2012 7 1

1.1.1.9 2018 1 1

1.1.2

1.1.2.1 [2011] 35

1.1.2.2 2013 37

1.1.2.3 2015 17

1.1.2.4 2016 31

1.1.2.5 44

1.1.2.6 < >

1

1.1.2.7 2011 21

1.1.2.8 39 2016 8 1

1.1.2.9 2018 1 1

1.1.2.10 2018 4 27

1.1.2.11 2018 9 29

1.1.2.12 2019 1 1

1.1.2.13 2014 19

1.1.2.14			4		
1.1.2.15					2012
	77				
1.1.2.16					2012 98
1.1.2.17					[2014]197
1.1.2.18		2009			
	10				
1.1.2.19					
					[2017]53
1.1.2.20					
			27	2015	7 10
1.1.2.21			2012-2020		[2012] 22
1.1.2.22					
	2017	1055			
1.1.2.23		VOCs			2013 31
	2013-05-24				
1.1.2.24					
					[2017]121
1.1.2.25					[2013]89
1.1.2.26					[2018]83
1.1.2.27					
1.1.2.28					
1.1.2.29					[2018]53
1.1.2.30		2010-2020			
1.1.3					
1.1.3.1					HJ2.1-2016

1.1.3.2 HJ 2.2-2018

1.1.3.3 HJ2.33-2018

1.1.3.4 HJ/T2.4-2009

1.1.3.5 HJ610-2016

1.1.3.6 2017 10 1

1.1.3.7 GB34330-2017

1.1.3.8 HJ169-2018

1.1.3.9 GB18218-2018

1.1.3.10 HJ 819-2017

1.1.3.11 (HJ 971-2018)

1.1.3.12 1

GB/T18075.1-2012

1.1.3.13

2016 21

1.1.3.14 2016 VOCs

2016 75

1.1.3.15

[2016]114

1.1.3.16

1.1.4

1.1.4.1

1.1.4.2

[2019]12

1.1.4.3

[2007]574

1.2

1.2.1

1.2.2

1.2.3

1.2.4

1.5.4

1.6

1.6.1

1.6.1.1

HJ2.2-2018

AERSCREEN

SO₂ NO_x

PM₁₀

Pi i

i

HJ2.2-2018

G2

1.00×10¹²m³/a

1-2

1-3

1-4

1-2

			/m		m				(h)	m/s		kg/h	(t/a)	C ₀ (ug/m ³)	P ₀ m ³ /a
			X	Y		(m)	(m)	()							
1		CO ₂ G1	521745.14	3507046.91	16	15	0.3	25	3720	16.1		0.001	0.004	450	8.889E+06
2		G2	521361.13	3507433.02	9	35	8 5.7	25	3800	7.15		0.032	0.12	200	1.000E+12
												0.989	3.76	2000	1.880E+09
												0.603	2.29	450	5.089E+09
											SO ₂	0.088	0.33	500	6.600E+08
											NO _x	0.412	1.56	250	6.240E+09
			0.434	1.65	2000	8.250E+08									
3		G3	521440.63	3507402.34	9	20	0.9	100	3800	16.11					

												NO _x	0.309	1.17	250	4.680E+09
													0.029	0.11	200	5.500E+08

5 G5 521437.96 3507376.06 9 20 0.9 100 3800 16.7

1-3

			mg/m ³	%	m
	G2	1	0.000595	0.30	274
	G5	1	0.000210	0.10	90
		1	0.000810	0.40	205
	G2	1	0.0184	0.92	274
	G3	1	0.00323	0.16	72
	G4	1	0.000701	0.04	62
	G5	1	0.00379	0.19	90
		1	0.0165	0.83	205
CO ₂	G1	1	0.0000951	0.02	90
	G2	1	0.0112	2.49	274
	G3	1	0.000253	0.06	72
	G4	1	0.000237	0.05	62
	G5	1	0.000224	0.05	90
	G6	1	0.000838	0.19	28
		1	0.00133	0.30	498
SO ₂	G2	1	0.00164	0.33	274
	G3	1	0.000714	0.14	72
	G4	1	0.000681	0.14	62
	G5	1	0.000636	0.13	90
	G6	1	0.00241	0.48	28
		1	0.00380	0.76	498
NO ₂	G2	1	0.00689	3.45	274
	G3	1	0.00301	1.50	72
	G4	1	0.00287	1.43	62
	G5	1	0.00268	1.34	90
	G6	1	0.0101	5.07	28
		1	0.0160	8.00	498

1-4	
	P_{max}
	$max < 10\%$
	$P_{max} < 1\%$

P_{max} 8.00% 10%
 1% $P_{max} < 10\%$

5km

1.6.1.2

B

1.6.1.3

HJ610-2016 2

1-5

1-5

$2.25km^2$

500m

1.6.1.4

GB3096-2008 3

200m

1m

GB12348-2008 3

200m

1.6.1.5

HJ169-2018

1-6

				a

a

1.6.2

1.7

1.7.1

1.7.1.1

GB3095-2012

1.7.1.2

HJ2.2-2018

D.1

0.2mg/m³

1.7.1.3

2.0mg/m³

1.7.1.4 GB3838-2002

1.7.1.5 GB/T14848-2017

1.7.1.6 GB3096-2008 3 4a

1.7.1.7 () (GB36600-2018)

1-7

		mg/m ³				
	PM ₁₀	0.15	mg/m ³	GB3095-2012		
	PM _{2.5}	0.075				
	SO ₂	0.15				
		1 0.50				
	NO ₂	0.08				
		1 0.20				
	O ₃	8 0.16				
		1 0.2				
		2.0				
		0.2				HJ2.2-2018 D.1
pH	6~9		mg/L	GB3838-2002		
	COD	30				
		1.5				
		0.05				
		0.3				
		2.0				
		/				
		1.5				
	LAS	0.3				
pH	6.5~8.5		mg/L	GB/T14848-93		
		450				
		1000				
		250				
		250				

1-7

		mg/m ³			
	N	20			
	N	0.02			
		0.2			
		0.05			
		0.05			
		0.1			
		1.0			
		0.3			
		0.05			
		1.0			
		3.0			
	LAS	0.3			
		3	4a	dB(A)	GB3096-2008 3
		65	70		
		55	55		
				4a	
		60	140	mg/kg	() (GB36600-2018)
		65	172		
		5.7	78		
		18000	36000		
		800	2500		
		38	82		
		900	200		
		2.8	36		
		0.9	10		
		37	120		
	1,1-	9	100		
	1,2-	5	21		

1-7

	mg/m ³		
1,1-	66	200	
-1,2-	596	2000	
-1,2-	54	163	
	616	2000	
1,2-	5	47	
1,1,1,2-	10	100	
1,1,2,2-	6.8	50	
	53	183	
1,1,1-	840	840	
1,1,2-	2.8	15	
	2.8	20	

1,2,3-

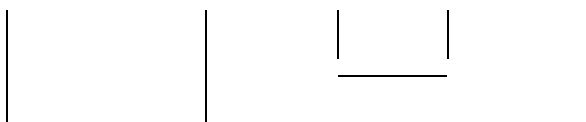

1-7

		mg/m ³			
	[a]	15	151		
	[a]	1.5	15		
	[b]	15	151		
	[k]	151	1500		
		1293	12900		
	[a,h]	1.5	15		
	[1,2,3-c,d]	15	151		
		70	700		

1.7.2

1.7.2.1 GB16297-1996 2

1.7.2.2 VOCs

DB12/ 524-2014 2

1.7.2.3 GB13271-2014 3

1.7.2.4

GB8978-1996 1 4

1.7.2.5 GB12348-2008 3 4

1.7.2.6 GB 12523-2011

1.7.2.7 GB18597-2001 2013

1.7.2.8 GB18599-2001 2013

1-8

		mg/m ³	mg/m ³		(kg/h)
--	--	-------------------	-------------------	--	--------

NO

1-8

mg/m³

1.8.2

1-9

1-1

1-9

			m	m		
(E 11.6%)	1		NNE	372	1270	72 1100
	2		NE	272	1234	5638 16914
	3		NE	530	1387	55 1116
	4		N	481	1435	700 2100
	5		NE	342	1259	168 504
	6		SE	1450	2088	120 360
	8		E	347	1031	20 60
	9		E	1265	2120	172 516

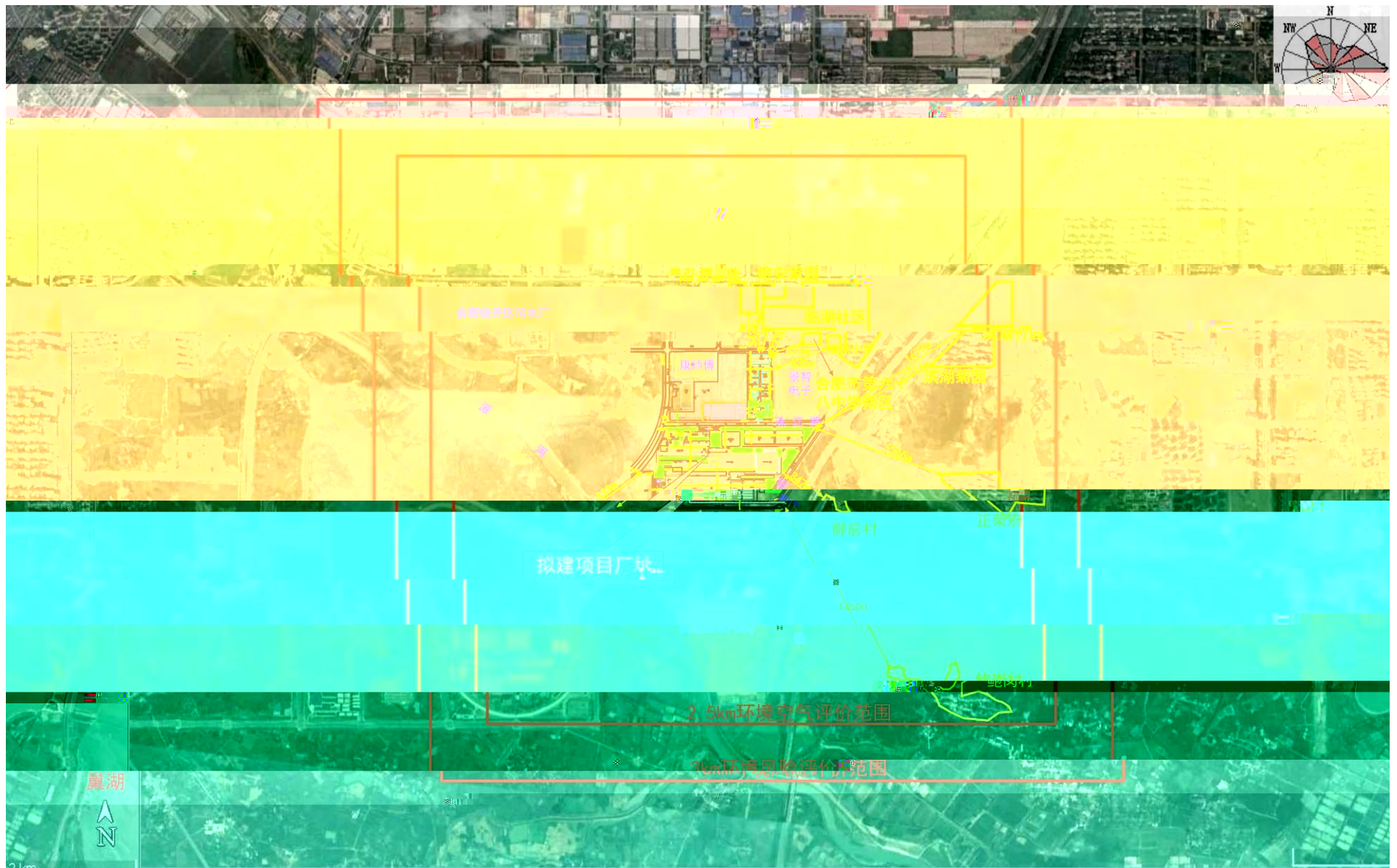

1-1

2

2.1

128.4hm²(1926)

117 °13'55.93"

31 °42'10.27"

2-1

2.2

506111

295153

210958

6486.44

506111

1.3%

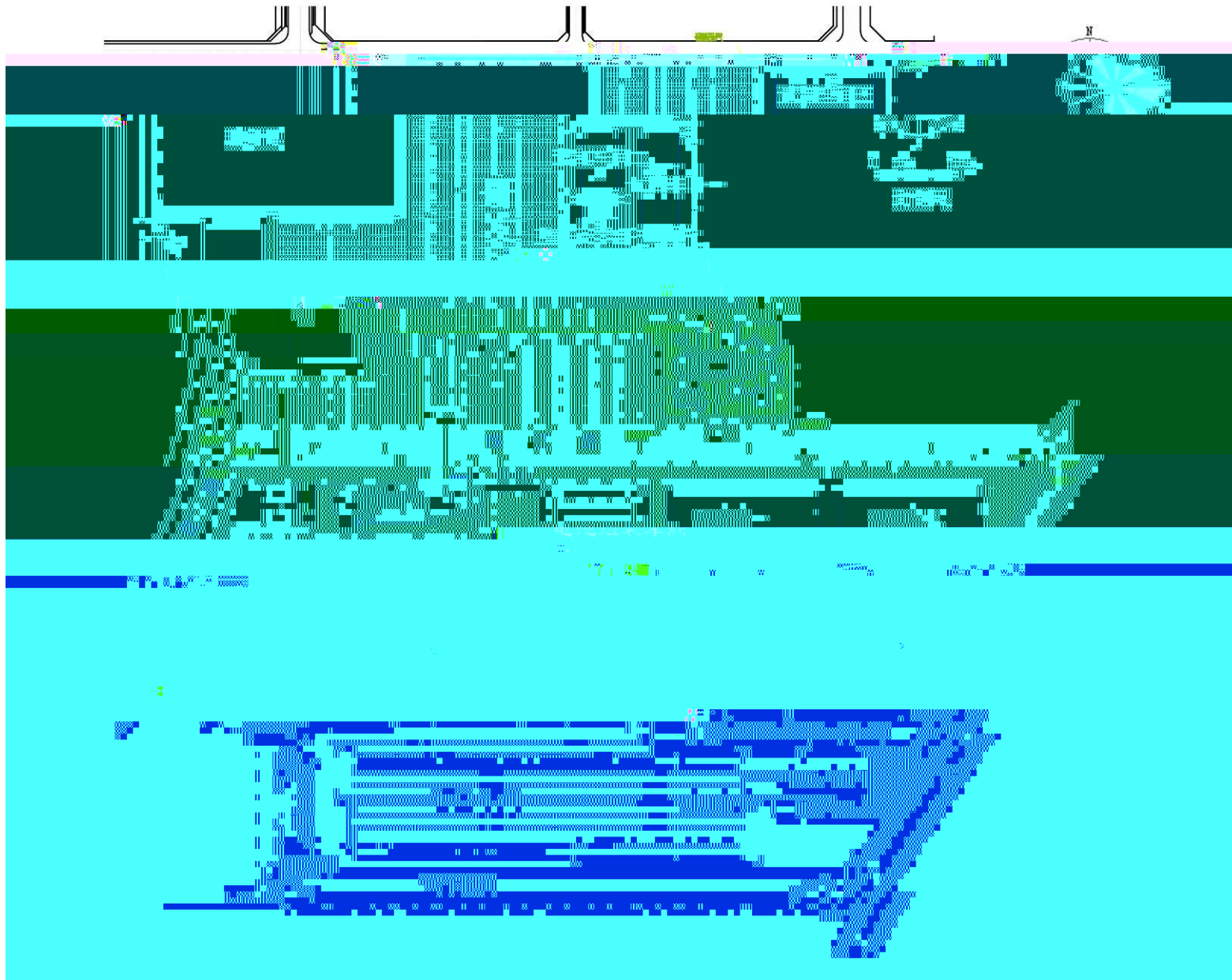

2-1

2.3



10 /

SUV A0

A MPV A

2-1

2-1

	A0 SUV	A SUV	A MPV
			
× × mm	4135 1750 1560	4780 1825 1745	4750 1795 1717
mm	2490	2760	2760
/ mm	1515/1500	1555/1550	1525/1520
kg	1460	1870	1840
	5	5	7
	85KW	110KW	110KW
kWh	40	58	58
km	250	300	300
km/h	130	130	130
0-100km/h	12S	12S	12S
h /	8/1.5	11/1.5	11/1.5
%	30	30	30

2.4

2019 5

2020 6

2.5

2-2

2-2

				m ²
1			1 1	146400
2			1 1	81000
3			1	136000
4			1	13000
1			/	
2			/	2268
3			/	30095.46
4				1000
5	3		/	79680
6			/	8050
7			/	3600
8				3240
9			/	/

2-2

				m ²
1	2		/	44544
2			/	/
3			/	/
4			/	41000
5			/	185000
1	2			8900
1			/	5000
2			/	1680

2.6

2-3

2-3

1		hm ²	128.4	1926
2		m ²	628237.46	/
3		m ²	937872.46	
4		m ²	708891.87	/
5				

2-4

12			1	
13			1	
14			1	
15			1	
16			1	
17			1	
18			1	
19			1	
20			10	
21			2	
22			1	
23			1	
24		DVT	3	
25			2	
27	AUDIT		1	
28			2	
29			21	
			62	
1			10	
2			2	
3			14	
4			2	
5			5	
6			1	
7			1	
			35	
			482	

2.8

2.8.1

2-5

2-6

2-7

2-8

2-5

1		t/a	70000	
2		t/a	12	
3	CO ₂	t/a	6	
4		t/a	146	NaOH LAS
5		t/a	165	H ₃ PO ₄
6		t/a	14	Na ₃ PO ₄
7		t/a	1028.21	8%
8		t/a	147	55% 25% 15% 5%
9		t/a	70	PVC 82% 10% 8%
10	B1	t/a	233.33	
11	B2	t/a	608.93	/
13		t/a	270	
14		t/a	56.4	
15		t/a	120	
16		t/a	139	PAM PAC
17		m ³ /a	271	

18		m ³ /a	150	
19		m ³ /a	115	
20		m ³ /a	64	
21		m ³ /a	400	
22		m ³ /a	800	
23		t/a	80	
24		/	10	
25		/	10	
26		/	10	
27		/	10	
28		/a	10	
29		/a	10	

2-6

	NaOH		PO ₄ ³⁻	LAS				
	20~32%	2~10%	0.5ppm	1~5%				
	10~15%	6%	6%					
	Zn(H ₂ PO ₄) ₂	Mn(H ₂ PO ₄) ₂	NaH ₂ PO ₄	NiNO ₃	H ₃ PO ₄		Fe(NO ₃) ₃	
	10~15%	5~10%	2~5%	5~10%	5~10%			
	10%	29%	8%					
B1	36%	15%	49%					
B2	20%	15%	65%					
	58%	5%	37%					

	100%							
	15%	85%						

2-7

	m ² /	(m ² /a)			g/cm ³	(m)		(t/a)
	120	1200	95%	50%	1.10	37	2	1028.21
B1	20	200	70%	36%	1.05	28	2	233.33
B2	25	250	70%	20%	1.10	31	1	608.93
	20	200	70%	58.6%	1.20	70	60~100	409.56

2-8

	1.5	pH	14	=1				LD ₅₀ 500mg/kg LD ₅₀ 5000mg/kg
					pH			
		8.5		=1	1.3			8.3
								8.1
								LD ₅₀ 1990 mg/kg
								LD ₅₀ 8290 mg/kg
	1		=1	1.4				LD ₅₀ 1520 mg/kg
								LD ₅₀ 1620 mg/kg
								LD ₅₀ 3250 mg/kg
								LD ₅₀ 1530 mg/kg
								LD ₅₀ N/A

	100	
B1	=1 62 >37.78	pH 8.5 1.01 LD ₅₀ 6019.4mg/kg LD ₅₀ 6298.9mg/kg
B2	=1 62 >37.78	pH 8.5 1.01 LD ₅₀ 10182.4mg/kg LD ₅₀ 9537.5mg/kg
	=1 30 0.98	LD ₅₀ 9404.4mg/kg LD ₅₀ 5516.8mg/kg

2.8.2

2-9

2-9

1		kWh/a	14489
2		m ³ /a	3.55
3		m ³ /a	579.5
4		m ³ /a	2574.99

2.9

2-10

2-10

1		
2		
3		
4		
5		
6	ABS	
7		
8		
9		
10	ECU	
11		
12		
13		
14		
15		
16		
17		
18		
19		
20		
21		
22		
23		
24		
25		
26		
27		
28		
29		
30		

2.10

2.10.1

1 35/10kV

10kV

2.10.2

1 DN250

0.20MPa

1

1

1

60m³/h 300m³/h 120m³/h 4992m³/h

2.10.3

2.10.4

1

20m³/h

70%

30%

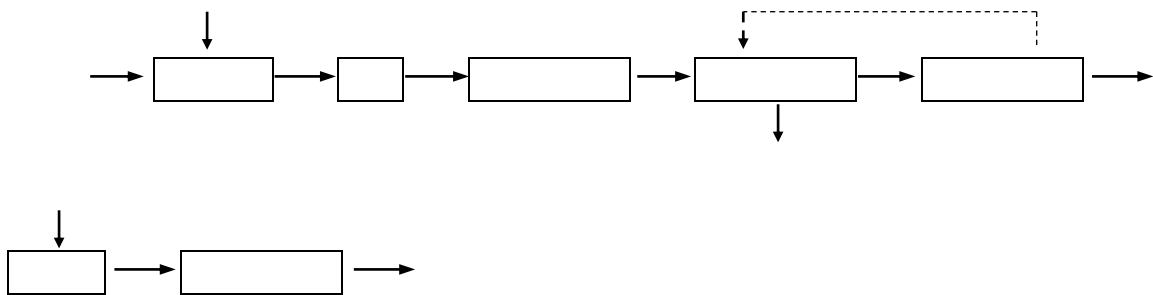

2.10.5

7

7

12

2.10.6

3

3.1

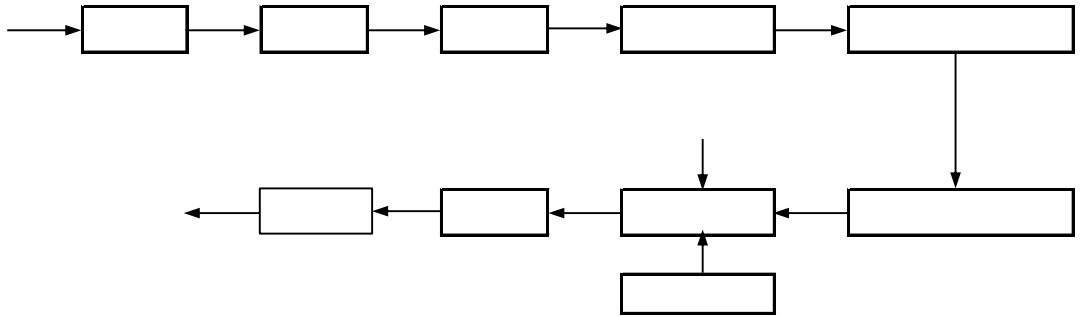

3-1

3.1.1

1

10

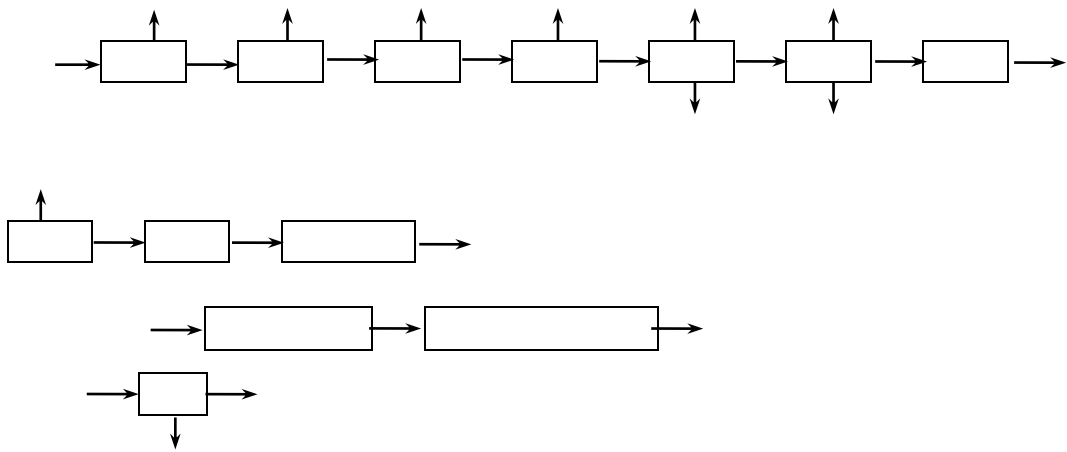

3-2

3.1.2

1

1

10

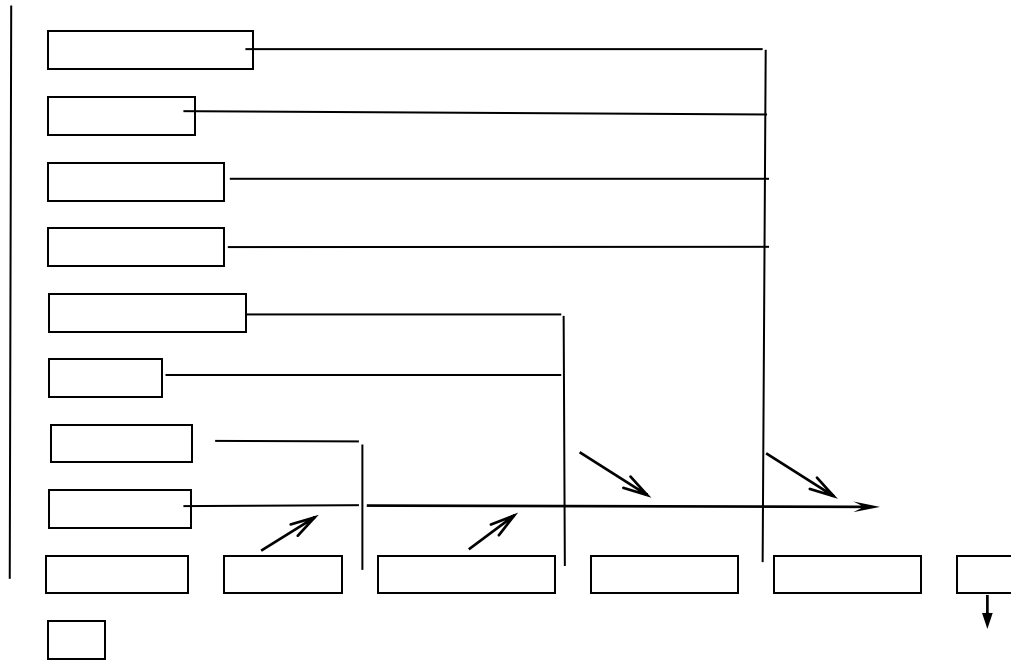

3-3

CO₂

3.1.3

1

10

PVC

B1

B2

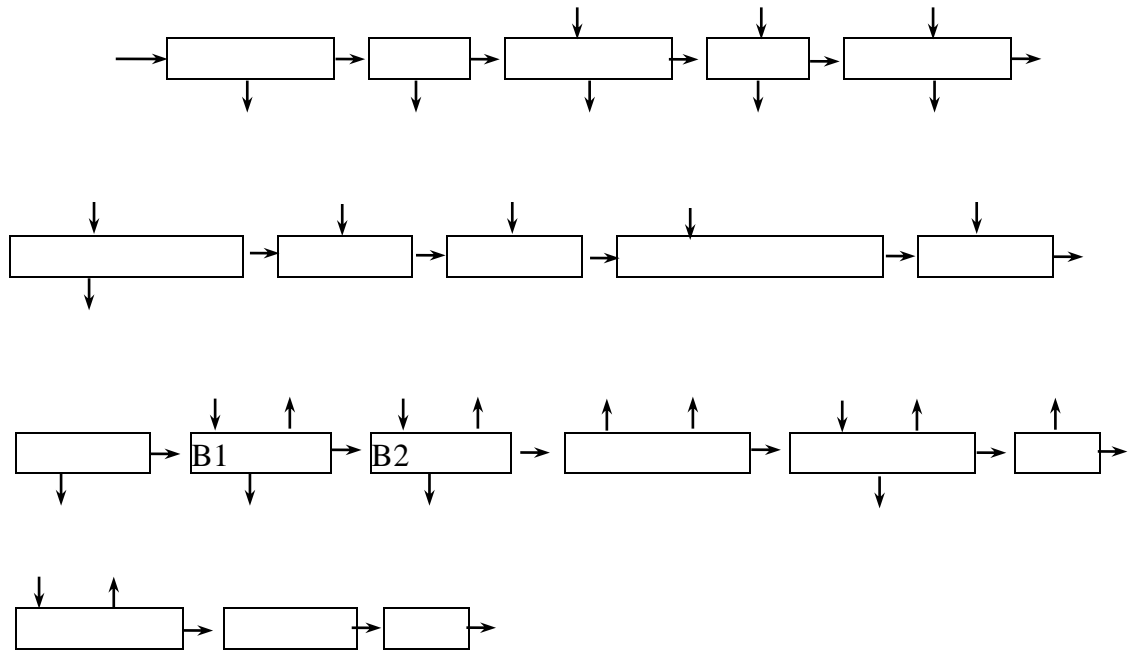

3-4

pH COD

SS

Zn Ni

pH COD SS

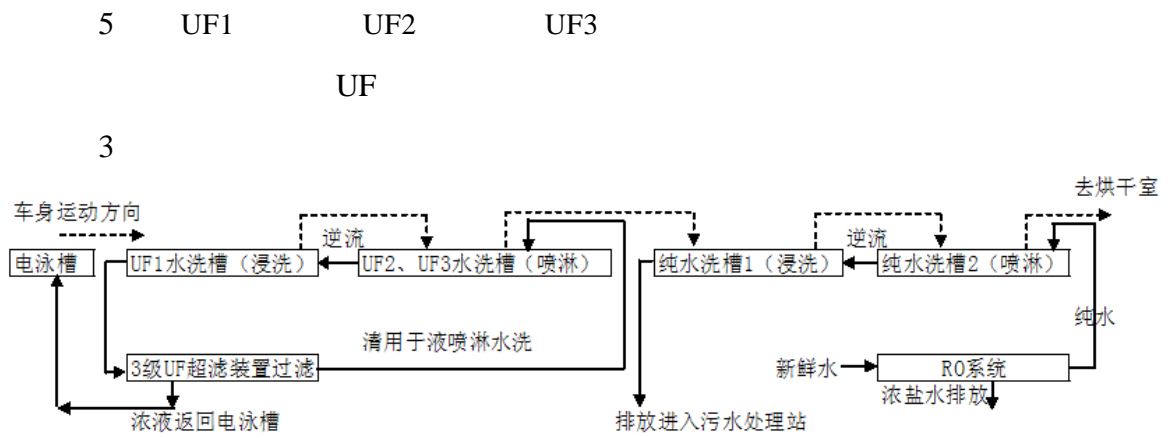

3-5

pH COD

SS

PVC
150 15
PVC

170

SS

B1 B2

2

B1 B2

B1

B2

B1

B2

B1 B2

B1

UV

B2

98%

B1 B2

5

30

60~80

10

180

150

30

SO₂ NO_x

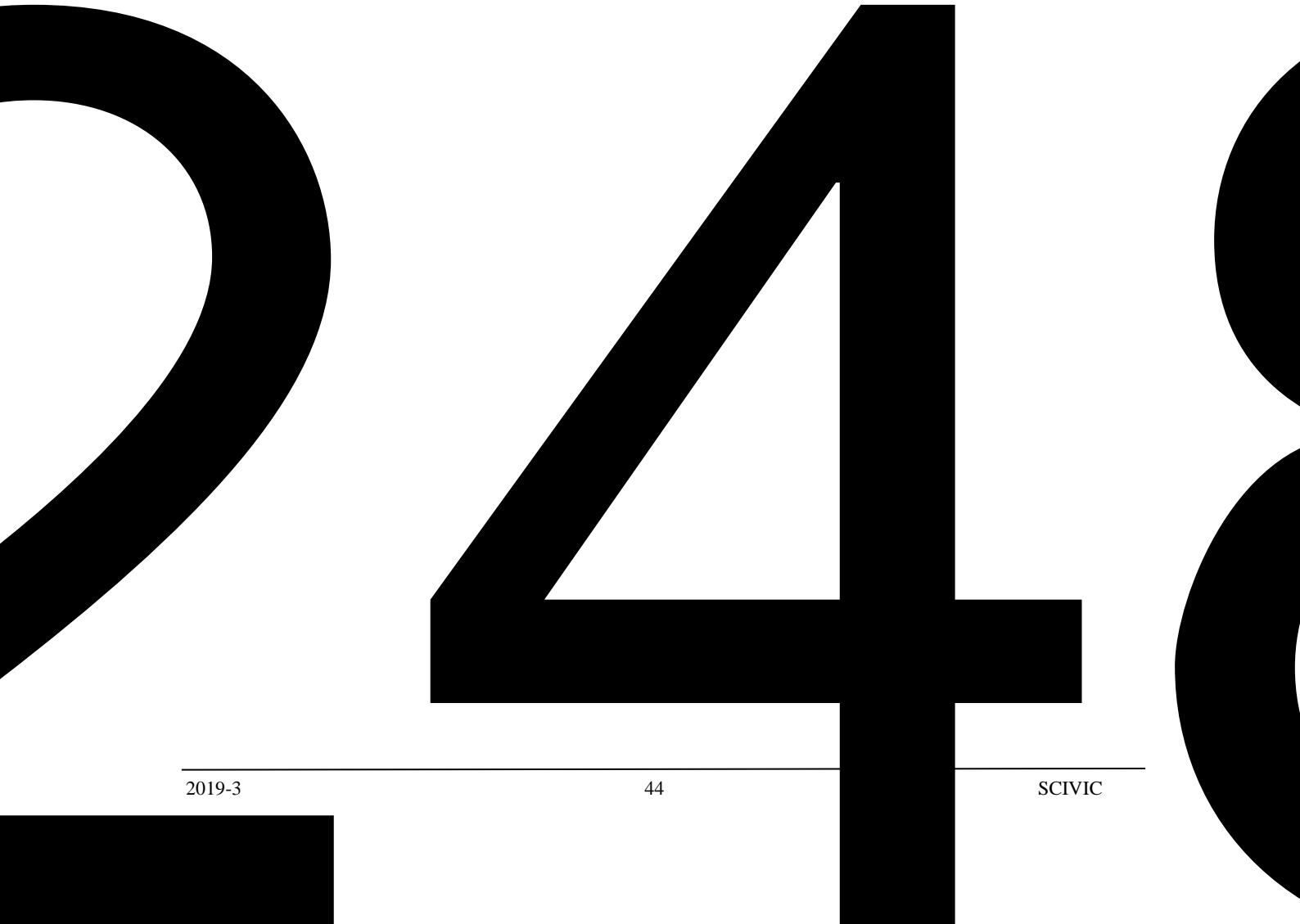

3.1.5

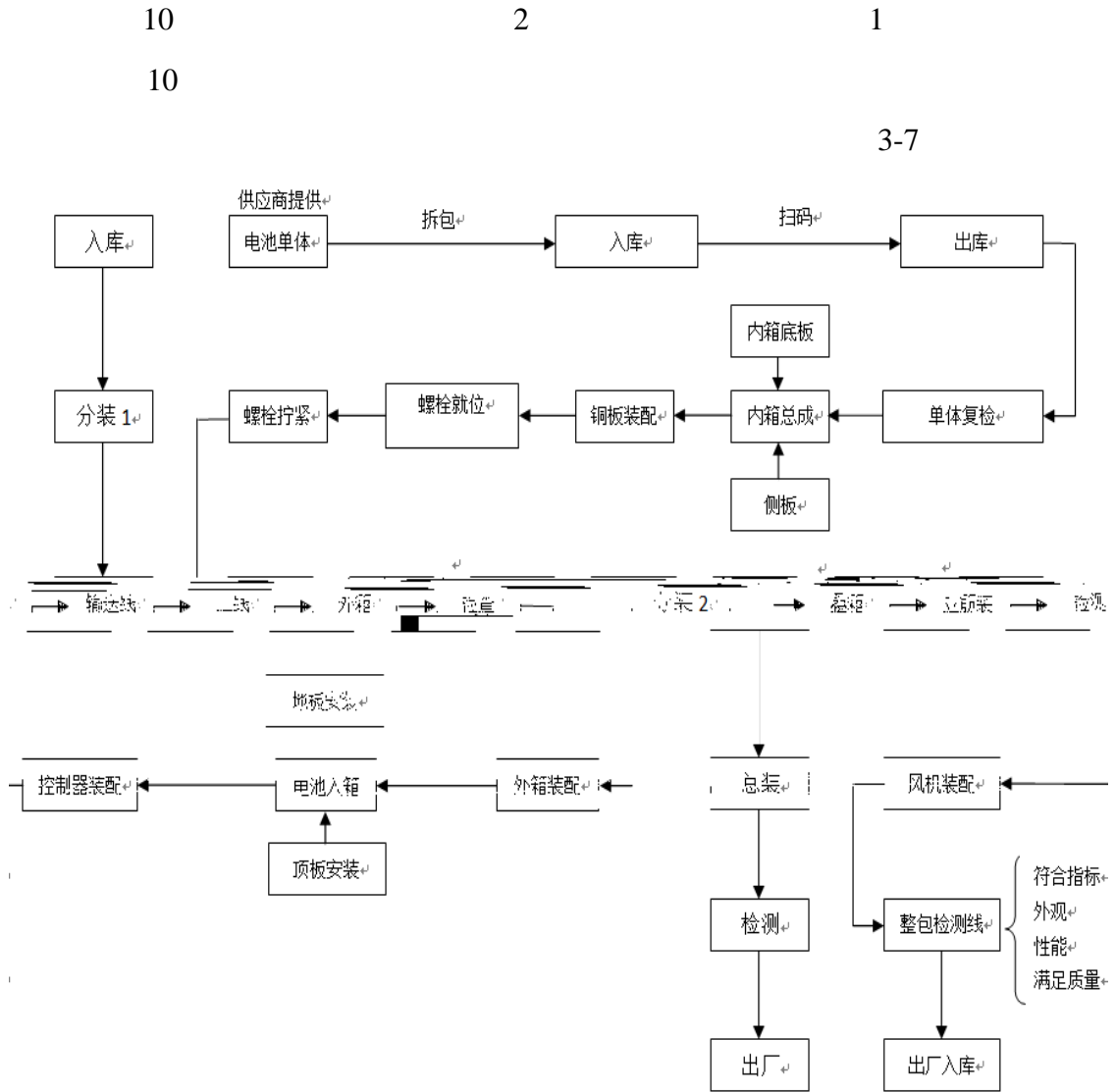

3-7

3.2

						10	/
B1	233.33t/a	B2	608.93t/a			270t/a	B1
B2		36%	20%	58%	B1	B2	
						5%	

1112.26t/a		13.5t/a	510.14t/a
56.4 t/a	85%		120 t/a
1028.21t/a		82.26 t/a	
		217t t/a	12.95t/a
3-8			

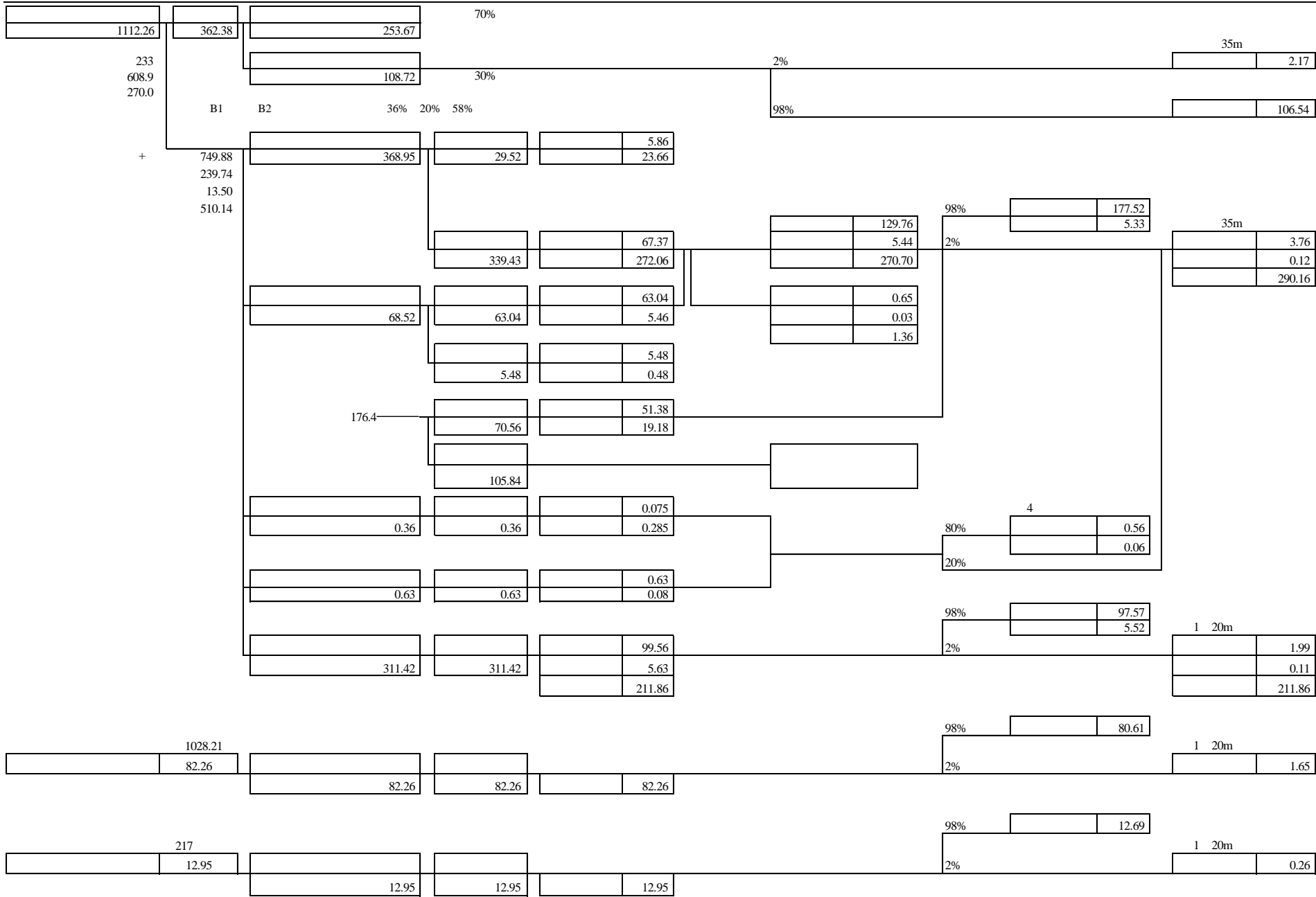

3-8

t/a

3.3

	45702.64m ³ /d	1775.70m ³ /d
150.94m ³ /d	43776.00m ³ /d	96.11%
387.04m ³ /d		
150.94m ³ /d	105.66 m ³ /d	
45.28m ³ /d	51m ³ /d	
	438.04m ³ /d	148.26m ³ /d
78.04m ³ /d		
	57.83 m ³ /d	
	3-1	3-9

3-1

m³/d

1.1		2.13				0.43	1.70			
1.2		10.80			8.64				2.16	
			8.64	480.00		5.18				3.46
2.1		54.00			43.20				10.80	
			43.20	2400.00		25.92				17.28
3										
3.1		202.18				20.22	181.96			
3.3		9.60				0.96	8.64			
3.4			158.11			15.81	142.30			
3.5		426.79			298.75				128.04	
3.6			140.64			14.06	126.58			
3.7		40.43				10.11	30.32			
3.8		399.36		39936.00		299.52				99.84
3.9		200.00				180.00				20.00
4		1.80				0.60	1.20			
5		24.00			19.20				4.80	
			19.20	960.00		11.52				7.68
6		60.00				9.00	51.00			
7		450.00				450.00				
8		68.04				10.21		57.83		
9		1949.11	369.80	43776.00	369.79	1053.53	492.70	51.00	145.80	148.26
10		45725.11					543.70			
11				95.74%			57.83			
12		11431277.61								
13		487277.61					601.53		294.05	

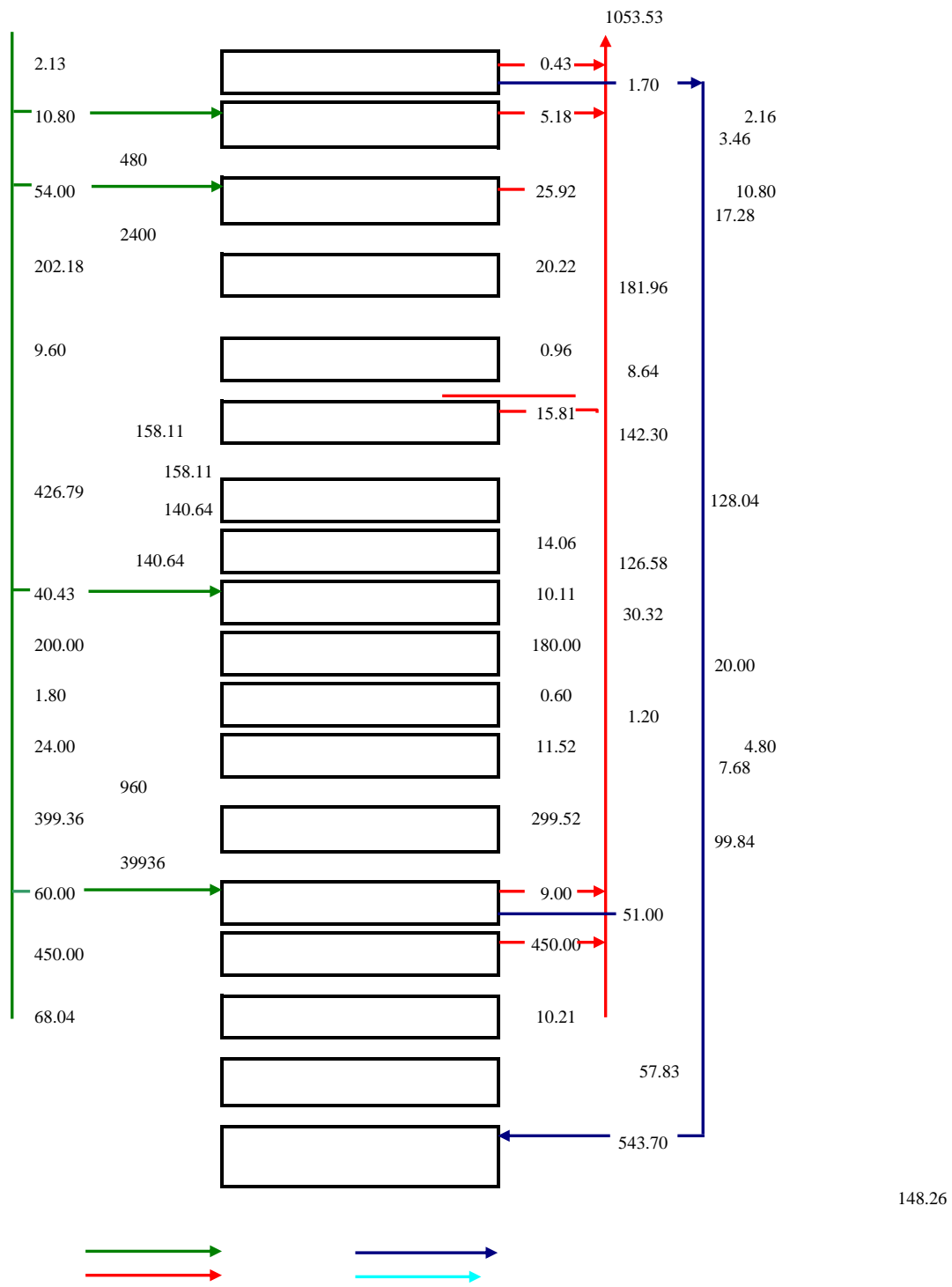

3-9

m³/d

3.4

3.4.1

CO₂

3.4.1.1

8 CO₂ 1t 7kg
 Fe₂O₃ MnO₂
 6t/a 0.01kg/h 0.042t/a
 CO₂ CO₂
 CO₂
 90 1 15m
 0.001kg/h 0.11mg/m³ GB16297-1996
 2 10000m³/h

GB16297-1996 2

3.4.1.2

B1
 B2
 A.
 1028.21t/a
 8% 21.65kg/h
 TNV
 98% 1 20m
 0.434kg/h 16.08mg/m³ 27000m³/h
 240m³/h
 2010 10 249
 SO₂ 0.02Skg/
 m³ S S 200mg/m³ NOx 18.71kg/
 m³ 1000m³ 0.14kg SO₂ NOx
 0.034kg/h 0.096kg/h 0.449kg/h 1.24mg/m³
 3.56mg/m³ 16.63mg/m³

				GB16297-1996	2
VOCs	0.43kg/h		16.08mg/m ³		
				DB12/ 524-2014	2
B.					
			5% 8%		
	3.41kg/h				
					98%
	1 20m				
0.068kg/h	4.56mg/m ³		15000m ³ /h		1 20m
			165m ³ /h	SO ₂ NO _x	
0.023kg/h	0.066kg/h	0.309kg/h		1.54mg/m ³	4.40mg/m ³
20.58mg/m ³					
				GB16297-1996	2
VOCs	0.068kg/h		4.56mg/m ³		
				DB12/ 524-2014	2
C.					
			B1	B2	
	B1	B2			
	B1	B2			
					98%
					92%

1 TNV
220m³/h

98% TNV

1 35m

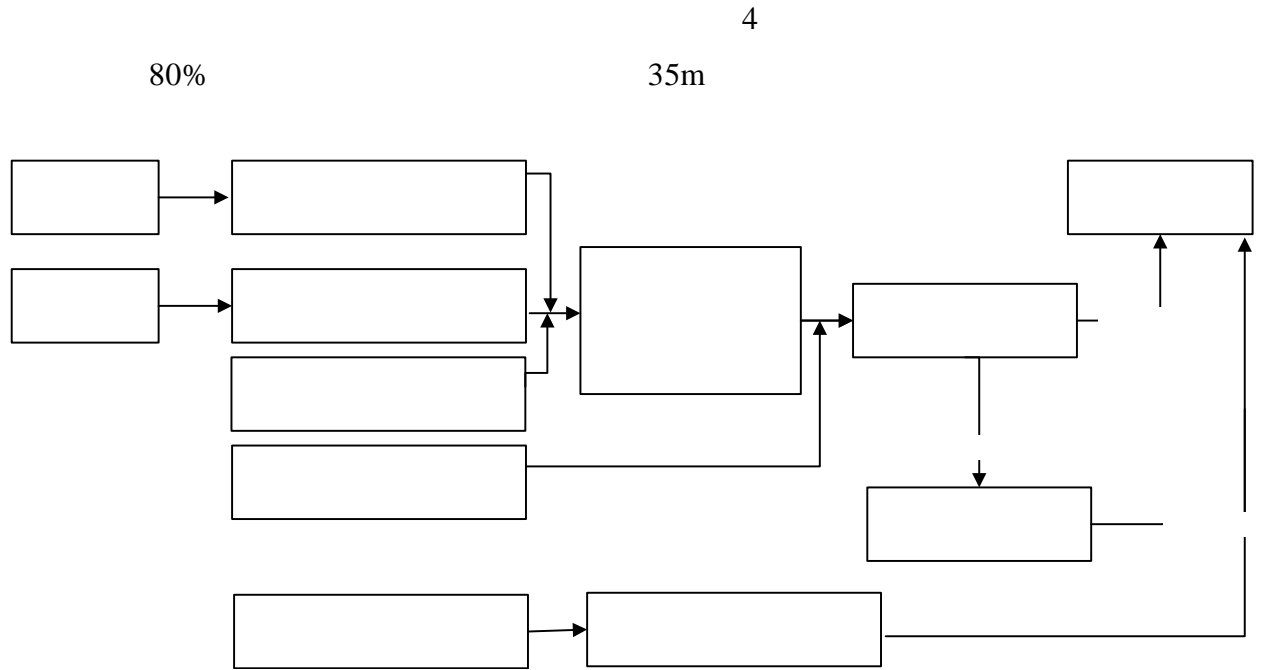

80%

35m

35m

0.032kg/h 0.989kg/h

0.08mg/m³ 2.57mg/m³

385000m³/h

220m³/h

SO₂ NO_x

0.031kg/h 0.088kg/h 0.412kg/h

0.08mg/m³

0.23mg/m³ 1.07mg/m³

GB16297-1996

2

VOCs

0.989kg/h

2.57mg/m³

DB12/

524-2014 2

E.

98%

0.029kg/h 0.524kg/h

1.03mg/m³ 18.70mg/m³

28000m³/h 1 20m

3-2

		m ³ /h	/		mg/ ³ m	kg/h	t/a		mg/ ³ m	kg/h	t/a	mg/ ³ m	kg/h	
1.1	CO ₂	10000	1 × 1.5 m / 0.2 m		1.05	0.01	0.042		0.11	0.001	0.004			
1.2														
2.1		385000	1 35 m / (8 × 5.7 m		74.31	28.61	108.72		1.49	0.572	2.17			
					4.06	1.56	5.94		0.08	0.032	0.12			
					124.25	47.84	181.79		2.57	0.989	3.76			
					0.08	0.031	0.12		0.08	0.031	0.12			
				SO ₂	0.23	0.088	0.33		0.23	0.088	0.33			
	NO _x	1.07	0.412	1.56		1.07	0.412	1.56						
2.2		27000	1 × 20 m / 0.		801.75	21.65	82.26	1 TNV 1 20m	98%	16.08	0.434	1.65		
					1.24	0.034	0.13	GB16297-1996	2	1.24	0.034	0.13		
				SO ₂	3.56	0.096	0.36	DB12/524-2014	2	3.56	0.096	0.36		
				NO _x	16.63	0.449	1.71			16.63	0.449	1.71		
2.3		15000	1 × 20 m / 0.		227.19	3.41	12.95	1 TNV 1 20m	98%	4.56	0.068	0.26		
					1.54	0.023	0.09	GB16297-1996	2	1.54	0.023	0.09		
				SO ₂	4.40	0.066	0.25	DB12/524-2014		4.40	0.066	0.25		
				NO _x	20.58	0.309	1.17			20.58	0.309	1.17		
2.4		28000	1 × 20 m / 0.		52.91	1.48	5.63	1 TNV 1 20m	98%	1.03	0.029	0.11		
					935.71	26.20	99.56	GB16297-1996	2	18.70	0.524	1.99		
					1.10	0.031	0.12	DB12/524-2014		1.10	0.031	0.12		
				SO ₂	3.14	0.088	0.33			3.14	0.088	0.33		
				NO _x	14.70	0.412	1.56			14.70	0.412	1.56		
2.5						0.056	0.21			0.056	0.21			
				SO ₂		0.160	0.61			0.160	0.61			
				NO _x		0.748	2.84			0.748	2.84			
2.6			408 × 108 × ()			0.008	0.03			0.008	0.03			
						0.163	0.65			0.163	0.65			
3		3815.2	1 × 1.5 m / 0.		10.27	0.039	0.15	1 15m		10.27	0.039	0.15		
				SO ₂	29.36	0.112	0.43	GB13271-2014	3	29.36	0.112	0.43		
				NO _x	137.31	0.524	1.99			137.31	0.524	1.99		
4		10000			15.00	0.150	0.15		1.50	0.015	0.015			

3.4.2

3.4.2.1

3-4

				(m ³ /d)	
1			6m ³ /	1.20	
			0.5m ³ /	0.50	
2			20m ³ /	0.96	
			28m ³ /3	9.33	
			15m ³ /	5	
			187m ³ /3	2.99	
			205m ³ /6	1.64	
			4m ³ /h	32	
			15m ³ /h	120	
			7m ³ /	1.40	
			90m ³ /	8.64	
			90m ³ /	8.64	
			195m ³ /6	1.56	
			215m ³ /6	1.72	
			15m ³ /h	120	
			7m ³ /	1.40	
			90m ³ /	8.64	
			7m ³ /	0.34	
			90m ³ /3	8.64	
			290m ³ /6	2.32	
		UF1	7m ³ /6	0.06	
		UF2	90m ³ /6	0.72	
		UF3	7m ³ /6	0.06	
			330m ³ /6	2.64	
			15m ³ /h	120	
			7m ³ /6	0.06	
			90m ³ /6	0.72	
			200m ³ /3	3.20	
		110m ³ /3	1.76		
		195m ³ /	9.36		
		2m ³ /h	16		
3			60m ³ /	1.2	
4			492.70m³/d		
5			51m³/d		
6			294.05m³/d		

3-4

				(m ³ /d)	
			837.75m³/d		
			57.83 m³/d		

3.4.2.3

1

57.83 m³/d

29.68 m³/d 28.15 m³/d 1 40m³

1 50m³

3-5

3-5

				mg/L				t/a	
	m ³ /d	m ³ /a		pH	SS	COD	BOD ₅		
	29.68	7420	()	6~9	120	300	262.5		16
	28.15	70375	()	6~9	175	297.5	198	38.8	
	57.83	144575		6~9	146.77	298.78	231.10	18.89	8.21
			/	2.12	4.32	3.34	0.27	0.12	
GB8978-1996	4			6~9	400	500	300	-	100

2

1

a.

Ni

150.94m³/d

GB8978-1996 1

15m³/h 240m³/d

3-10

b.

57.74m³/d + 284.02m³/d 341.76m³/d

SBR + +

GB 8978-1996

4

5000m² 3-6

3-7

3-11

3-6

	+	15m ³ /h 240m ³ /d	150.94m ³ /d
	+	10m ³ /h 160m ³ /d	57.74m ³ /d
		30m ³ /h 480m ³ /d	341.76m ³ /d
	(SBR+ +)	30m ³ /h 720m ³ /d	543.7m ³ /d

3-7

				mg/L						t/a		
	m ³ /d	m ³ /a		pH	SS	COD		Zn	Ni		BOD ₅	
	543.7	135925			39.27	231.14	9.47	1.214	1.123	7.187	2.81	0.51

3-7

				mg/L							t/a	
	m ³ /d	m ³ /a		pH	SS	COD		Zn	Ni		BOD ₅	
	15094	37735		6~9	19	123		0.32	0.30	1.90		
	543.7	135925		7~9	55	299	7.17	0.09	0.08	0.53	20.64	3.75
	543.7	135925		7~9	17	150	5.73	0.09	0.08	0.05	4.13	0.75
				2.26	20.32	0.78	0.012	0.011	0.007	0.56	0.102	
GB8978-1996	1	4		6~9	400	500	20	5.0	1.0	-	300	-
				6~9	200	330	-	-	-	0.5	160	15

表

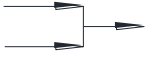

3-10

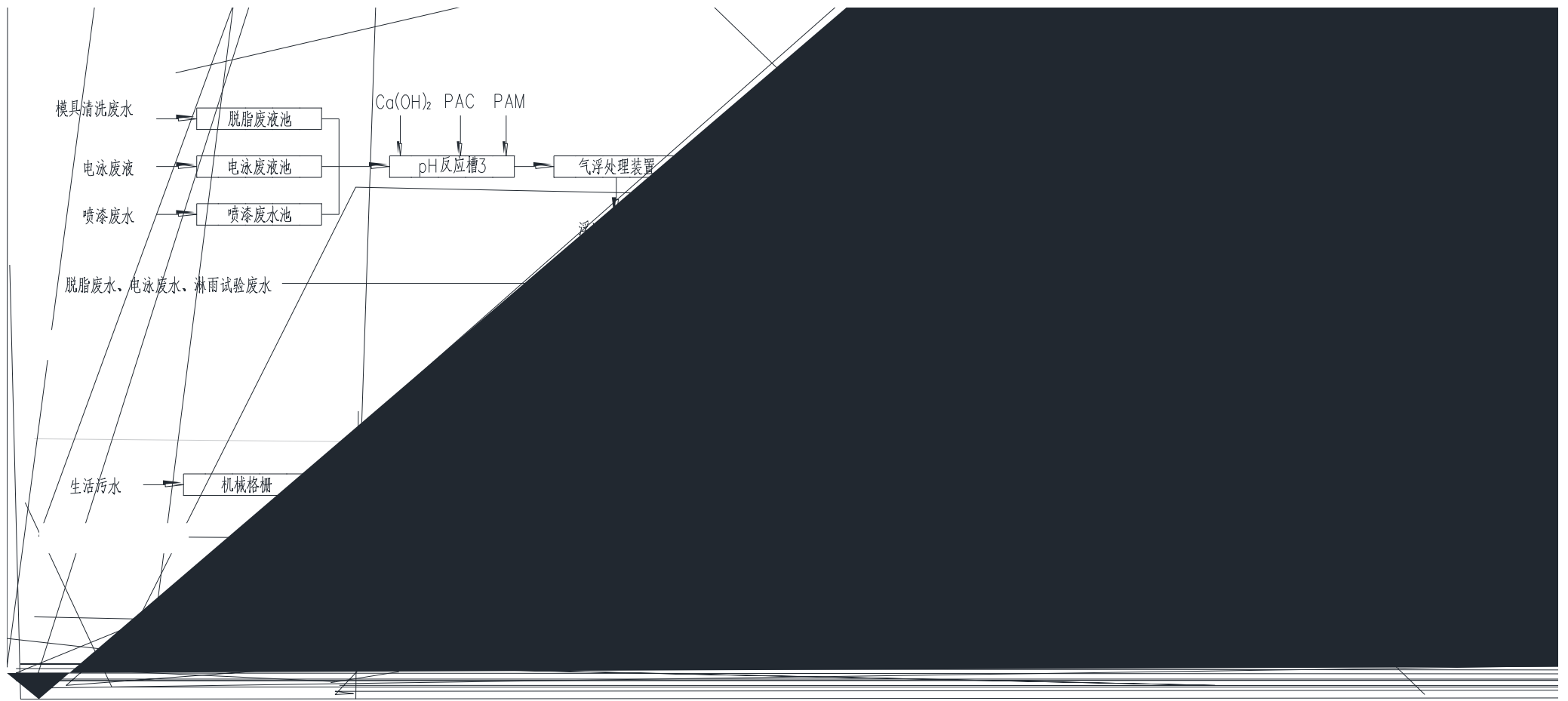

3-11

3.4.3

75~95dB(A)

3-8

3-8			dB(A)			
		5	90~95			70~75
			90~95			65~75
			85~90			
		6	80			< 65
		7	80~85			60~65
			80~85			60~65
		5	80~85			60~65
			85~90			65~70
			75~85			65~70

60~75dB(A)

3.4.4

		12t		12t/a	
		4	3		500kg
		6t/a			
0.5t/a	15%			1.5/a	42%
0.705t/a		2.35t/a			3.06t/a

1.5t/a

42%

0.63t/a

2.1t/a

2.73t/a

106.54t/a

50%

213.08t/a

1

80g

8.0t/a

176.4t

10

10t

1t/a

131.6t/a

3t/a

GB34330-2017

120m²

GB18597-2001

1m

3-9

3-10

3-9

t/a

3-10

				t/a							
1		HW08	900-217-08	12					1	T I	
2		HW49	900-041-49	11.79						T/In	
3		HW12	264-011-12	213.08						T	
4		HW17	336-064-17	8						T/C	
5		HW12	900-252-12	176.4						T	
6		HW49	900-041								

3.5

3-11

3-11		t/a			
		m ³ /a	181949.8	0	181949.8
		t/a	109.57	106.58	2.99
		t/a	0.85	0.038	0.816
		t/a	108.72	106.55	2.17
		t/a	377.21	368.90	8.31
		t/a	11.60	11.34	0.26
	SO ₂	t/a	2.32	0	2.32
	NO _x	t/a	10.84	0	10.84
	(m ³ /a)	m ³ /a	150382.5	0	150382.5
	(m ³ /a)	m ³ /a	73512.5	0	73512.5
	SS	t/a	43.26	38.88	4.38
	COD	t/a	238.05	213.41	24.64
		t/a	9.47	8.69	0.78
		t/a	7.187	7.180	0.007
		t/a	1.214	1.202	0.012
		t/a	1.123	1.112	0.011

3-12

						I	II	III		
1	0.53				0.10	a b c	a b		I	
2				--	0.10	a b c	a b d c	a b	II	
3					0.06		c			I
4				--	0.10	i c				II
5				--	0.06	c	j	f		I
6					0.06					8% I
7				--	0.05		UV	c		I

3-12

						I	II	III	
						e ^c e	e	e	TNV I
8					0.06	e	j	j	I
9				--	0.08	VOCs VOCs	VOCs VOCs	VOCs VOCs	+TNV 98% VOCs I
10				--	0.08	VOCs VOCs	VOCs VOCs	VOCs	VOCs TNV VOCs I
11				--	0.03	f	g		(55 5) II

3-12

I

II

III

h

12

-- 0.03

3-12

						I	II	III		
20		0.25	COD _{Cr} *		g/m ²	0.33		4	8	9.91 I
21			*		g/m ²	0.17		4	6	0.3 I
22			*		g/m ²	0.17		60	240	46.41 I
23			VOCs *		g/m ²	0.33	35	40	45	31.43 II
				g/m ²			60	80	/	
24		0.1			--	0.05				I
25					--	0.05	18597	GB 18599		GB I
26					--	0.05				I

3-12

						I	II	III	
27				--	0.05				I
28				--	0.05				I
29				--	0.05	GB/T 24001			I
30				--	0.05	VOCs			I
31				--	0.05				I
32				--	0.05				I
33				--	0.05				I
34				--	0.10				I
35				--	0.10				I
36				--	0.10				I

3-13

	Y 85
	Y 85
	Y =100

3-13

Y_{II}=100

3-14

4

4.1

4.1.1

~

~

40

1993

2000

206 405 312

11km

4km

117 °13'49.19"

31 °42'11.75"

272m

4-1

4-2

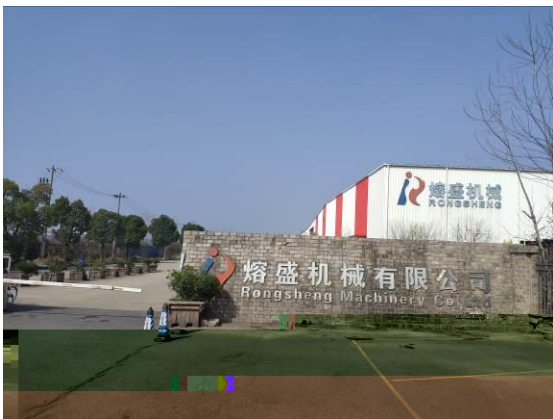

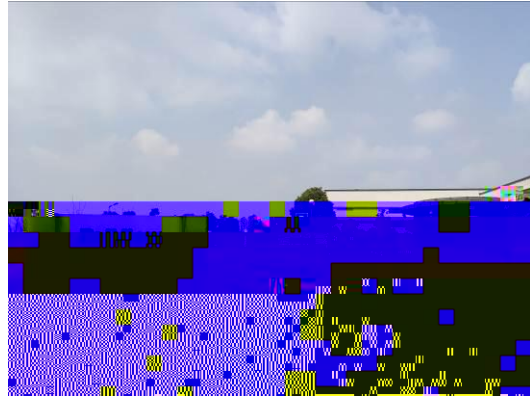

4-1

4.1.2

		12	45				10.4
43.4m		8.4	10.4m				
				5%	87.2%	7.8%	
282			158				
		2.5	2.8kg/cm				10-15
							294
	3		1977				
		7			38		
15	70						



4-2

4.1.3

85%

()

4.1.4

1012.5hPa 2.8m/s 16.5 995.4mm

4.1.5

1

9131km² 800km² 1/3
33 30 m³
19 m³ 8.31m 760km²
3394.9km²
267.47
60km 571km²
1.8 m³/a

4.1.6

				30 t/d			
10 t/d	2007	6				10 t/d	2011
				10 t/d	2016		
	15.6 m ²			61.33km ²		9.3 m ²	
		A ² /O		V			
				GB18918-2002		A	5 t/d

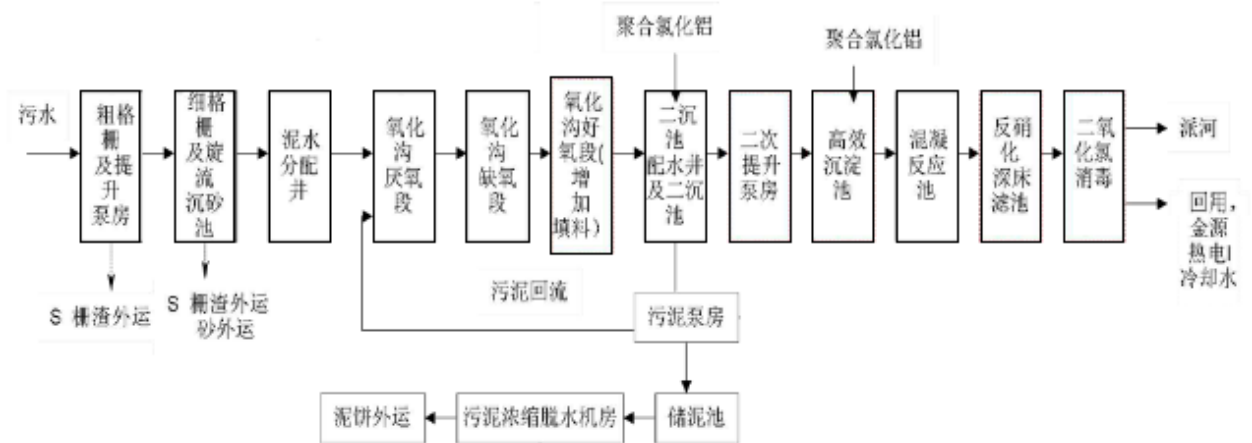

4.2

3

5

5.1

5.1.1

		2018	5	2017	
SO ₂		12	/		
NO ₂		52	/		0.3
CO	95	1.4	/		
O ₃	8	90		170	/
0.06					
	PM ₁₀		80	/	
0.14					
	(PM _{2.5})	56	/		0.6

2017

5.1.2

(HJ2.2-2018) 5.5

3 1 6.2
1

2017

() (HJ663-2013) 1

SO ₂	NO ₂	24	98	CO
24	95		O ₃	8
	PM ₁₀	PM _{2.5}	24	95

5-1 2017

	1	2	3	4	5	6	7	8	9	10	11	12
	88	64	47	47	32	40	28	25	28			

5.2

5.2.1

2
5-3 5-1 2019 3 13 ~2019
3 19

5-3

1#			/
2#		W	4100m

5.2.2

7 4
2:00 8:00 14:00 20:00 45

5.2.3

5-4 5-4 mg/m³

5.2.5

$$Pi = \frac{Ci}{Si}$$

Pi

Si

mg/m³

Ci

mg/m³

5.2.6

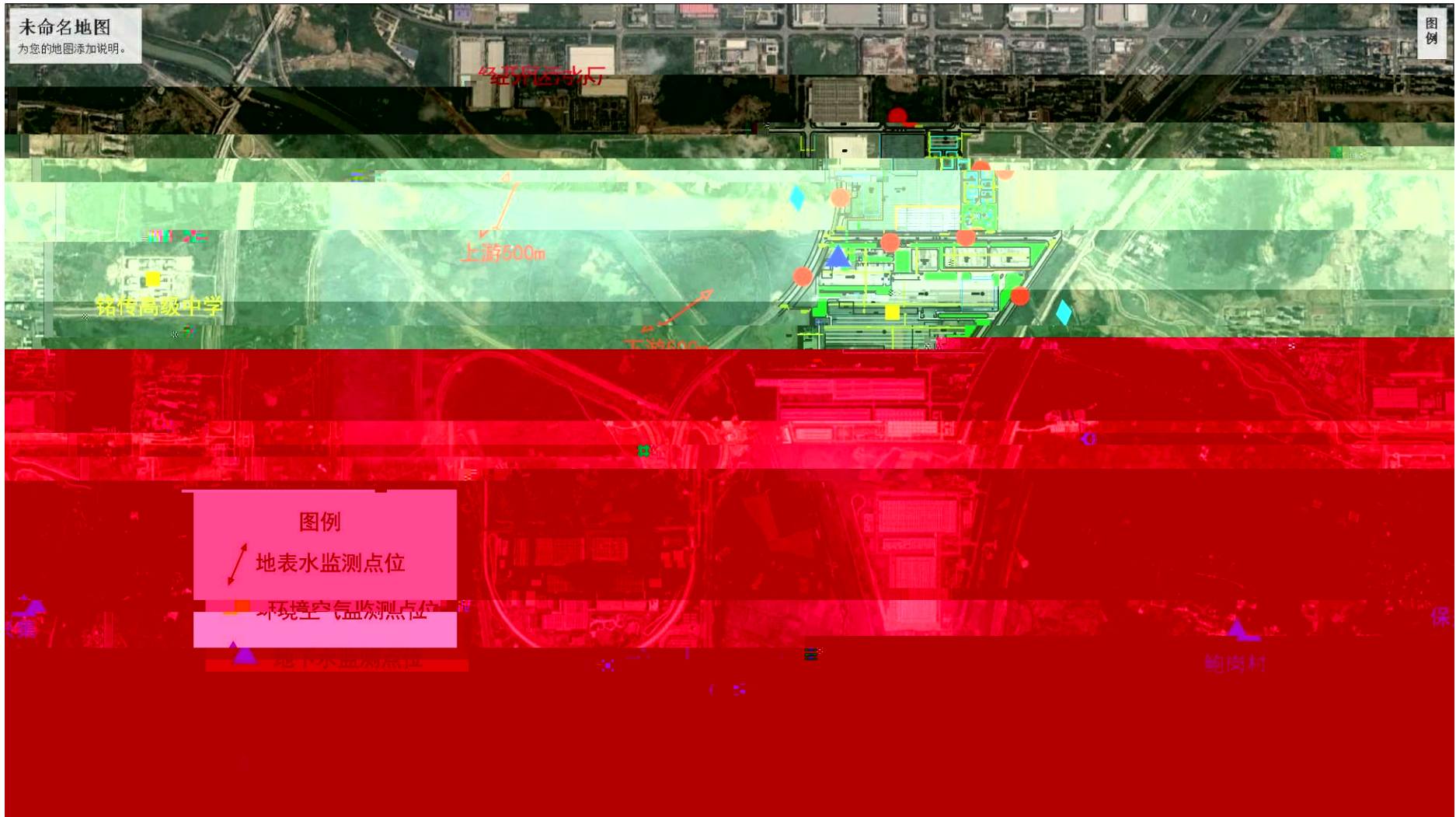

5-1

5-6

5-6

mg/m³

		mg/m ³			Pi		
	20190313	ND	ND	0.538	/	/	0.269
	20190314	ND	ND	0.530	/	/	0.265
	20190315	ND	ND	0.490	/	/	0.245
	20190316	ND	ND	0.405	/	/	0.203
	20190317	ND	ND	0.443	/	/	0.222
	20190318	ND	ND	0.523	/	/	0.262
	20190319	ND	ND	0.395	/	/	0.198
	20190313	ND	ND	0.515	/	/	0.258
	20190314	ND	ND	0.455	/	/	0.228
	20190315	ND	ND	0.525	/	/	0.263
	20190316	ND	ND	0.450	/	/	0.225
	20190317	ND	ND	0.463	/	/	0.232
	20190318	ND	ND	0.470	/	/	0.235
	20190319	ND	ND	0.435	/	/	0.218

5-6

0.395~0.538mg/m³

0.198~0.269

5.3

5.3.1

5.3.1.1

2 5-7 5-1
 2019 3 13 ~2019 3 15

5-7

1#		500m	
2#		500m	

5.3.1.2

pH COD NH₃-N LAS

5.3.1.3

5-8

5-8

1	pH	pH 2002	/
2	COD	HJ 828-2017	4mg/L
3		HJ535-2009	0.025mg/L
4		HJ 637-2012	0.04mg/L
5	P	GB/T 11893-1989	0.01mg/L
6		GB/T 7484-1987	0.05mg/L
7	LAS	GB/T 7494-1987	0.05mg/L
8		32	0.007mg/L
9		HJ 776-2015	

5-9	mg/L pH	
	1#	2#
pH	6~9	
COD	30	
	5	
P	3	
	1.5	
LAS		
	/	
	2.0	

5.3.1.5

5.3.1.6

5-10

5-11

5-10

		mg/L pH			
		20190313	20190314	20190315	
500m	pH	7.38	7.31	7.34	6~9
	COD	24	22	25	30
		1.46	1.33	1.29	5
	P	0.22	0.21	0.23	3
		0.33	0.28	0.28	1.5
		ND	ND	ND	
	LAS	ND	ND	ND	
		ND	ND	ND	/
		ND	ND	ND	2.0
	pH	7.22	7.34	7.37	6~9
	COD	18	22	17	30

500m		1.34	1.29	1.42	5
		0.23	0.24	0.18	
	P	0.26	0.21	0.24	/
		ND	ND	ND	1.0
	LAS	ND	ND	ND	
		ND	ND	ND	
		ND	ND	ND	0.05

5-11

		mg/L pH					
		20190313	20190314	20190315	20190313	20190314	20190315
500m	pH	0.190	0.155	0.170	/	/	/
	COD	0.800	0.733	0.833	/	/	/
		0.973	0.887	0.860	/	/	/
		0.733	0.700	0.767	/	/	/
	P	0.220	0.187	0.187	/	/	/
		0.800	0.733	0.833	/	/	/
	LAS	0	0	0	/	/	/
		0	0	0	/	/	/
		0	0	0	/	/	/
1500m	pH	0.110	0.170	0.185	/	/	/
	COD	0.600	0.733	0.567	/	/	/
		0.893	0.860	0.947	/	/	/
		0.767	0.800	0.600	/	/	/
	P	0.173	0.140	0.160	/	/	/
		0.600	0.733	0.567	/	/	/
		0	0	0	/	/	/

	LAS						
		0	0	0	/	/	/
		0	0	0	/	/	/

0

5-11 5-12

LAS

GB3838-2002

5.4

3

2019 3 13

5.4.1

5-13

5-1

5-13

1#			
2#	SE 2000m		
3#	SE 2600m		

5.4.2

K⁺ Na⁺ Ca²⁺ Mg²⁺ CO₃²⁻ HCO₃⁻ Cl⁻ SO₄²⁻ pH

LAS

25

5.4.3

5-14

5-14

1	K ⁺	GB/T	0.05 mg/L
2	Na ⁺	11904-1989	0.01 mg/L
3	Ca ²⁺	GB/T	0.02 mg/L
4	Mg ²⁺	11905-1989	0.002 mg/L
5	CO ₃ ²⁻	HJ84-2016	0.01mg/L
6	HCO ₃ ⁻		

5-14

7	Cl ⁻	F ⁻ Cl ⁻ NO ₂ ⁻ Br ⁻ NO ₃ ⁻ PO ₄ ³⁻	0.007mg/L
8	SO ₄ ²⁻	SO ₃ ²⁻ SO ₄ ²⁻ HJ 84-2016	0.018mg/L
9	pH	pH 2002	/
10		HJ 535-2009	0.025mg/L
11		F ⁻ Cl ⁻ NO ₂ ⁻ Br ⁻ NO ₃ ⁻ PO ₄ ³⁻ SO ₃ ²⁻ SO ₄ ²⁻ HJ 84-2016	0.016
12		GB/T 7493-1987	0.02 mg/L
13		GB/T 7467-1987	0.004mg/L
14		EDTA 7477-1987	5 mg/L
15		GB/T 7475-1987	0.01mg/L
16		GB/T	0.03mg/L
17		11911-1989	0.01mg/L
18		32	0.007 mg/L
19		HJ 776-2015	0.02 mg/L
20		GB/T 5750.4-2006	/
21		GB/T 7494-1987	0.05 mg/L
22		GB/T 11892-1989	0.5 mg/L
23		HJ 488-2009	0.02 mg/L
24		HJ 970-2018	0.01 mg/L
25		GB/T 5750.5-2006	0.1 mg/L

5.4.3.1

GB/T14848-2017

5-15

5.4.3.2

5-15

5-15		mg/L pH		
\	1#	2#	3#	GB/T14848-2017
K ⁺	2.25	2.71	2.28	/
Na ⁺	14.9	12.4	15.3	200
Ca ²⁺	36.2	33.9	32.4	/
Mg ²⁺	7.33	5.36	7.24	/
CO ₃ ²⁻ mmol/L	47.6	45.8	43.2	/
HCO ₃ ⁻ mmol/L	41.8	37.3	40.7	/
mg/L	13.5	14.5	12.6	250
mg/L	14.6	16.8	13.4	250
pH	7.14	7.26	7.26	

1m

4 2019

3 13 5-16 5-1

5.5.2

5-16 5-17
dB(A)

5-16			
1#	1m		3
2#	1m		
3#	1m		
4#	1m		

5-17			
1#	1m		4a
2#	1m		3
3#	1m		
4#	1m		

5.5.3

5-18

5-18 dB(A)

2019 3 16 2019 3 17

5-18

GB3096-2008 3 4a

5.6

2019 3 14

5.6.1

3

5-19

5-19

				1	pH
					pH 45
	100m				pH
	100m				
	0 0.2m	0 0.5m	0.5 1.5m	1.5 3m	

5.6.2

5-20

5-20

1		GB/T22105.2-2008	0.01mg/kg
2		GB/T17141-1997	0.01mg/kg
3		HJ491-2009	5mg/kg
4		GB/T17138-1997	1mg/kg
5		GB/T22105.1-2008	0.002mg/kg
6		GB/T17141-1997	0.1mg/kg
7		HJ/T17139-1997	5.0mg/kg
8		/	0.02mg/kg
9			0.02mg/kg
10	-1,2-		0.02mg/kg

5-20

11	1,1-		0.02mg/kg
12	-1,2-		0.008mg/kg
13			0.02mg/kg
14	1,1,1-		0.02mg/kg
15			0.03mg/kg
16	1,2- +		0.01mg/kg
17			0.009mg/kg
18	1,2-		0.008mg/kg
19			0.006mg/kg
20	1,1,2-		0.02mg/kg
21			0.02mg/kg
22			0.005mg/kg
23	1,1,1,2-		0.02mg/kg
24			0.006mg/kg
25	+ -		0.009mg/kg
26	-		0.02mg/kg
27			0.02mg/kg
28	1,1,2,2-		0.02mg/kg

5.6.3

5-21

5-21										mg/kg
										GB36600-2018
	0.5m	1.0m	2.0m	0.5m	1.0m	2.0m	0.5m	1.0m	2.0m	
pH	6.82	6.78	6.78	6.74	6.77	6.73	6.82	6.81	6.77	/
	2.15	1.86	1.93	5.23	5.27	3.66	2.46	2.53	2.17	60
	0.34	0.27	0.28	0.38	0.41	0.32	0.37	0.45	0.29	65
	12.7	10.9	11.7	14.2	14.8	11.4	15.1	12.9	14.3	/
	<2.0	<2.0	<2.0	<2.0	<2.0	<2.0	<2.0	<2.0	<2.0	5.7
	34.4	28.6	31.7	35.2	41.1	36.0	38.3	32.9	31.7	18000
	12.7	10.7	12.5	14.2	12.9	13.3	13.3	12.9	11.8	800
	0.23 3	0.214	0.246	0.273	0.225	0.218	0.230	0.227	0.204	38
	16.1	13.2	14.5	14.2	13.7	13.4	15.6	10.2	14.7	900
	52.1	57.9	64.5	46.8	43.9	54.2	57.1	57.2	54.3	_____

1,1-	<0.02	9
-1,2-	<0.008	596
	<0.02	0.9
1,1,1-	<0.02	840
	<0.03	53
1,2-	<0.01	5
	<0.009	2.8
1,2-	<0.008	5
	<0.006	1200
1,1,2-	<0.02	2.8
	<0.02	53
	<.005	270
1,1,1,2-	<0.02	10
	<0.006	28
+ -	<0.009	570
-	<0.02	640
	<0.02	1290
1,1,2,2-	<0.02	6.8
1,2,3-	<0.02	0.5
1,4-	<0.008	20
1,2-	<0.02	560
	<0.003	70
2-	<0.06	2256
	<0.09	76
	<0.08	260
	<0.03	37
a	<0.004	15
a	<0.005	1.5
b	<0.005	15
k	<0.005	151
	<0.003	1293
a h	<0.005	1.5
1,2,3-cd	<0.004	15

GB36600-2018

GB12523-2011

6-1 68

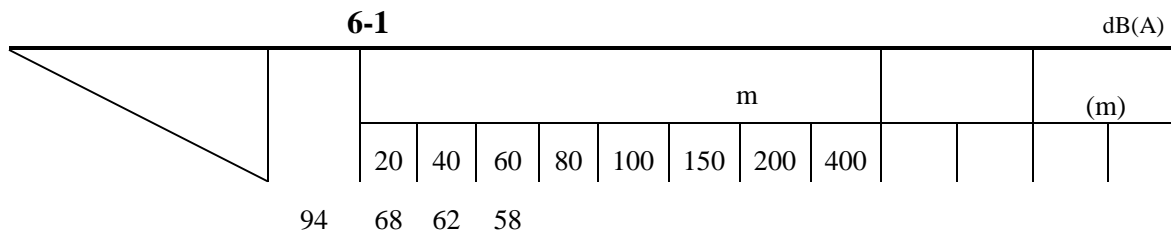

B.

C.

6.3

6.3.1

6.3.1.1

A.

B.

C.

D.

6.3.1.2

6.3.2

6.3.2.1

150m

TSP

1.5

GB 3095-2012

0.30mg/m³

1.6

6.3.2.2

600m

6.3.3

6.3.3.1

A.

70%

B.

C.

D.

E.

F.

6.3.3.2

6.3.4

6.3.4.1

COD

SS

COD BOD₅ SS

6.3.4.2

A.

B.

C.

6.4

6.5

6.5.1

7

7.1

7.1.1

7.1.1.1

(1998 ~2017)

117 18 E 31 47 N 27m

7.1.1.2

7.1.1.3

7-1

7-1

	1	2	3	4	5	6	7	8	9	10	11	12	
	3.0	5.9	10.2	16.6	22	25.6	28.6	27.7	23.7	18	11.2	5.5	16.5

7-1

16.5

7

28.6

1

3.0

7.1.1.4

7-2

7-2

	1	2	3	4	5	6	7	8	9	10	11	12	
--	---	---	---	---	---	---	---	---	---	----	----	----	--

m/s 2.5 2.7 3 3.1 2.9

	/m	90
	/km	/
	/	/

7.1.2

7.1.2.1

CO₂

SO₂ NO₂

7-5

7-5

	g/m ³	
	200	HJ2.2-2018 D.1
	2000	DB13/1577-2012 1
SO ₂	500	GB3095-2012
NO ₂	200	
	450	

HJ2.2-2018

7.1.2.2

7-6

7-6

			/m		m				(h)	m/s		kg/h	(t/a)	C ₀ (ug/m ³)	P ₀ m ³ /a
			X	Y		(m)	(m)	()							
1		CO ₂ G1	521745.14	3507046.91	16	15	0.3	25	3720	16.1		0.001	0.004	450	8.889E+06
5		G2	521361.13	3507433.02	9	35	8 5.7	25	3800	7.15		0.032	0.12	200	1.000E+12
												0.989	3.76	2000	1.880E+09
												0.603	2.29	450	5.089E+09
											SO ₂	0.088	0.33	500	6.600E+08
												0.412	1.56	250	6.240E+09
		0.434	1.65	2000	8.250E+08										
6		G3	521440.63	3507402.34	9	20	0.9	100	3800	16.1					

												NO _x	0.309	1.17	250	4.680E+09
10	G5	521437.96	3507376.06	9	20	0.9	100	3800		16.7		0.029	0.11	200	5.500E+08	
												0.524	1.99	2000	9.950E+08	
												0.031	0.12	450	2.667E+08	
											SO ₂	0.088	0.33	500	6.600E+08	
											NO _x	0.412	1.56	250	6.240E+09	
11	G6	522174.03	3507975.12	14	15	0.4	150	/		11.5 2		0.039	0.15	450	3.333E+08	
											SO ₂	0.112	0.43	500	8.600E+08	
											NO _x	0.524	1.99	250	7.960E+09	

h

7.1.2.3

A

SO₂ NO₂

7-8

7-8

			mg/m ³	%	m
	G2	1	0.000595	0.30	274
	G5	1	0.000210	0.10	90
		1	0.000810	0.40	205
	G2	1	0.0184	0.92	274
	G3	1	0.00323	0.16	72
	G4	1	0.000701	0.04	62
	G5	1	0.00379	0.19	90
		1	0.0165	0.83	205
CO ₂	G1	1	0.0000951	0.02	90
	G2	1	0.0112	2.49	274
	G3	1	0.000253	0.06	72
	G4	1	0.000237	0.05	62
	G5	1	0.000224	0.05	90
	G6	1	0.000838	0.19	28
		1	0.00133	0.30	498
SO ₂	G2	1	0.00164	0.33	274
	G3	1	0.000714	0.14	72
	G4	1	0.000681	0.14	62
	G5	1	0.000636	0.13	90
	G6	1	0.00241	0.48	28
		1	0.00380	0.76	498
NO ₂	G2	1	0.00689	3.45	274
	G3	1	0.00301	1.50	72

7-8

			mg/m ³	%	m
	G4	1	0.00287	1.43	62
	G5	1	0.00268	1.34	90
	G6	1	0.0101	5.07	28
		1	0.0160	8.00	498

SO₂ NO₂
 0.000810mg/m³ 0.0184mg/m³ 0.0112mg/m³ 0.00380mg/m³ 0.0160mg/m³
 0.40% 0.92% 2.49% 0.76% 8.00% SO₂ NO₂
 498m GB3095-2012
 274m
 205m
 - 2018 D
 205m
 DB13/1577-2012 1

SO₂ NO₂
 B

HJ2.2-2018

7-9

7-9

			mg/m ³	kg/h	(h)	t/a
			0.08	3.04	3800	0.12
1			2.57	0.47		3.76

	G2		1.57	0.13		2.29
		SO ₂	0.23	0.59		0.33
		NO _x	1.07	0.54		1.56
2	G3		16.08	0.434	3800	1.65
			1.24	0.034		0.13
		SO ₂	3.56	0.096		0.36
		NO _x	16.63	0.449		1.71
3	G4		4.56	0.068	3800	0.26
			1.54	0.023		0.09
		SO ₂	4.40	0.066		0.25
		NO _x	20.58	0.309		1.17
4	G5		1.03	0.029	3800	0.11
			18.70	0.524		1.99
			1.10	0.031		0.12
		SO ₂	3.14	0.088		0.33
		NO _x	14.70	0.412		1.56
						0.23
						7.66
						2.63
			SO ₂			1.27
			NO _x			6.00
1	CO ₂ G1		0.11	0.001	3720	0.004
2	G6		10.27	0.039	/	0.15
		SO ₂	29.36	0.112		0.43
		NO _x	137.31	0.524		1.99
						0.154
			SO ₂			0.43
			NO _x			1.99
						0.23
						7.66
						2.78
			SO ₂			1.70
			NO _x			7.99

7-10

7-10

							t/a
						mg/m ³	
1				DB12/ 524-2014	2	2	0.65
						0.2	0.03

2

GB16297-1996

7.66t/a 0.23t/a 1.70t/a 7.99t/a 2.78t/a
 SO₂ NO_x 0.03t/a 0.65t/a
 0.32t/a 0.91t/a 4.27t/a
 SO₂ NO_x 0.26t/a 8.31t/a 3.10t/a 2.61t/a 12.26t/a
 C

7-12

7-12		mg/m ³	
		mg/m ³	%
		0.000120	0.06
		0.000245	

DB12/ 524-2014
2

0.2mg/m³
2.0mg/m³

4

7.2.2

30 t/d

10 t/d	2007	6		10 t/d	2011
				10 t/d	2016
	15.6	m ²		61.33	km ²
				9.3	m ²
					895.58
					m ³ /d
			30	m ³ /d	0.3%

GB18918-2002

A

7.3

7.3.1

7.3.1.1

2-3m

				1~4
	11.3	/	pH	7.7~8.3
0.9-1.5	/			

		40-60	70	10
	2800	/		
		20-52	1400-2400	/
7.3.1.2				
	10.2~11.3m	58.8m		-
		4	1	

100L/d

COD

SS

15t/d

SS

2

895.58m³/d

pH COD

SS

7.3.2.2

1

2

50

1

HJ610-2016

$$\frac{C}{C_0} = \frac{1}{2} \operatorname{erfc} \left(\frac{x - ut}{2\sqrt{D_L t}} \right) + \frac{1}{2} e^{\frac{ux}{D_L}} \operatorname{erfc} \left(\frac{x + ut}{2\sqrt{D_L t}} \right)$$

x t d

C(x,t) t x g/L

C₀ g/L

u m/d

D_L m²/d

erfc

2

n u

D_L

1 n

- n

0.18

2 u

B K 1.5m/d

I 2

$$u = KI/n = 0.017 \text{ m/d}$$

3 x DL

L

10m

7-14

7-14

	k m/d	I	n	u m/d	m ² /d
	1.5	2	0.18	0.017	0.17

3

7-15

7-15

mg/L		m	m
8.26	100	6	15
	1000	31	59
	3650	85	142
	7300	155	237
69.63	100	19	24
	1000	73	90
	3650	168	201
	7300	273	315

100d 6m 15m 1000d 31m
 59m 10 85m 142m 20 155m
 237m 100d 19m

24m 1000d
201m 20

73m
273m

90m 10
315m

168m

08J333

1

7.4

7.4.1

75~95dB(A)

60~75dB(A)

3 3-8

7-16

700m

7-16

	(m) × ×	m			
	216×78×10	47	/	165	/
	408×108×16	/	27	/	136
	96×50×5	/	38	107	/
	60×40×6	31	/	/	/

200m

7.4.2

7.4.2.1

	A_{div}	A_{atm}	A_{gr}
A_{bar}	A_{misc}		

$$L_p(r) = L_p(r_0) - (A_{div} + A_{atm} + A_{gr} + A_{bar} + A_{misc})$$

7.4.2.2

$$L_p(r) = L_p(r_0) - 20 \lg(r/r_0)$$

$$A_{div} = 20 \lg(r/r_0)$$

7.4.2.3

$$L_p(r) = L_p(r_0) - 10 \lg(r/r_0)$$

$$A_{div} = 10 \lg(r/r_0)$$

7.4.2.4

7.4.2.5

200m

22:00~6:00

7-17			dB(A)	
1		48.3	65	
2		54.6		
3		43.5		
4		53.4		

7-17

GB 12348-2008 3

7-3

7.5

7.5.1

3-9 3-10

7.5.2

120m²

GB18597-2001

1m

GB18597-2001

6.2 6.3.1 6.3.9 6.3.11

8

8.1

8.1.1

COD 50000mg/L
(HJ169-2018) B

8-1

		CAS	/t
1		1330-20-7	10
2		/	10

8.1.1

8-2

8-2

1						
2						

8.2

8.2.1

P

8.2.1.1

Q

Q

8-3

8-3

Q

			CAS	/t	/t	Q
1		COD	/	330	10	33

2			1330-20-7	3.24	10	0.324

8.2.1.2

M

(HJ169-2018)

C

C.1

M=5

M4

8.2.1.3

P

(HJ169-2018)

C

C.2

8-3

M4

P4

8-4

P

Q	M			
	M1	M2	M3	M4
Q 100	P1	P1	P2	P3
Q 100	P1	P2	P3	P4
Q 10	P2	P3	P4	P4

8.2.2

E

8.2.2.1

E

1-1

(HJ169-2018)

D

D.1

5km

81670

E1

8.2.2.2

E

E3

8.2.2.3

E

(HJ169-2018)

D

D.5

G3

D2

E3

8.2.3

8-5

E	P			
	P1	P3	P3	P4
E1				
E2				
E3				

8-5

8.2.4

HJ169-2018

8-6

				a

a

8.3

8.3.1

8.3.2

8-7

8-7

1		
2		0.2m

A.

8-8

8-8

È" 52P5hl

B.

GB50183-2004

10^{-6} 1970 1992 22

7.75×10^{-4}

C.

53.5

14.1 16.9

5.3

25%

a.

b.

8.3.4

1

19747mg/m^3

50L

1.0g/mL

5

15

$$G_s = 5.38 + 4.1u \quad P_H F M^{1/2}$$

G_s

g/h

u

m/s

F

m²

5m²

M

106

P_H

mmHg

4.5mmHg

0.054kg/min

GBZ 2.1-2007

15

8-9

	mg/m ³	m	m
	3637	2	0
	GBZ 2-2002	m	
	100	50	

8.4

8.4.1

C30

1.0×10⁻¹⁰cm/s

GB18599-2001

100~150mm

200~250mm

2.0mm

300g/m²

2

220m³

20L/s

8.5

8.6

8.6.1

8.6.2

8.6.3

A.

B.

C.

D.

E.

a.

b.

c.

d.

e.

f.

F.

a.

120

b.

c.

d.

G.

H.

8.6.4

A.

B.

8.7

8-10

8-10

	1				
	2			1	119
	3				
	4				119
	5				119
	6				119

8.8

8-11

8-11

1			
2			2
3		220 m ³	25
4		200m ³	10

C.

9.1.3

A.

B.

C.

9.1.4

9.1.5

9.2

9.2.1

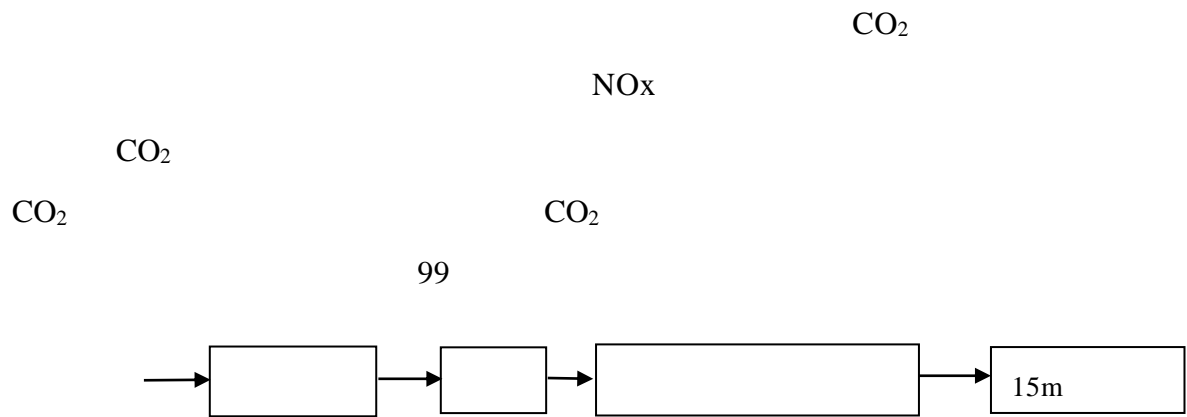

GB16297-1996

9.2.2

9.2.2.1

70%

B1

B2

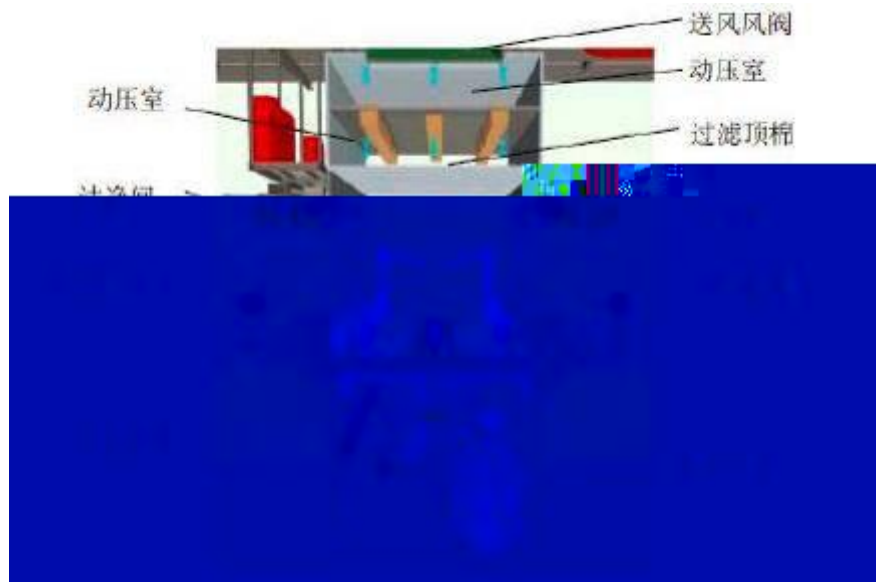

9-1

98%

+

35m

A.

92%

35m

1~6

1 15m

80%

VOCs

DB12/ 524-2014 2

9.2.2.3

TNV

350

650 760

CO₂ H₂O

98%

27m

TNV

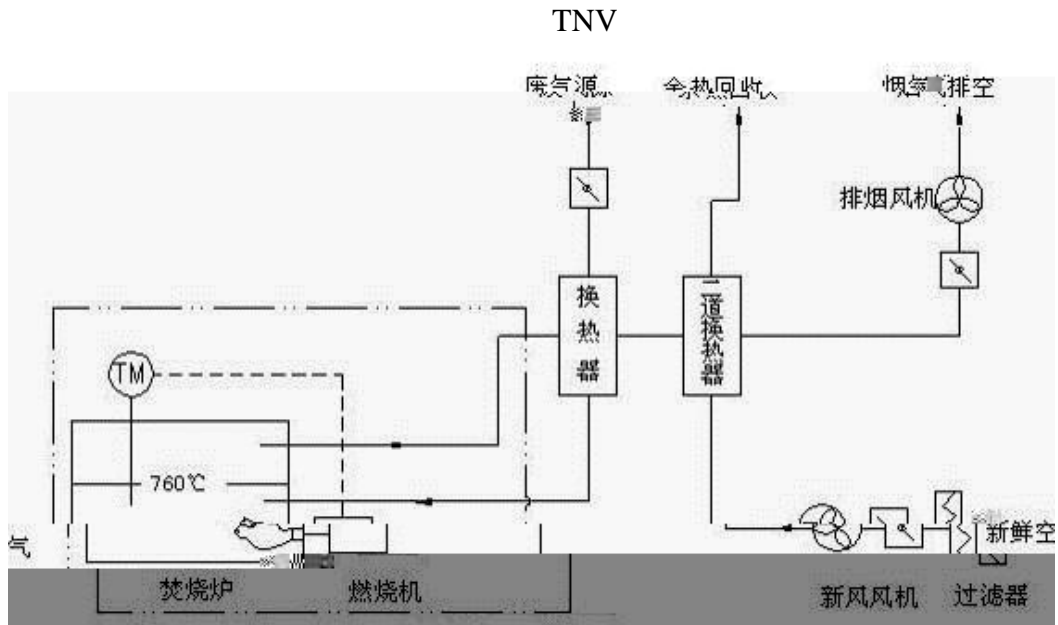

GB16297-1996

2

VOCs

b.

pH 3 pH pH 8~9
 PAC PAM

c.

 pH 4 PAC PAM
 2 SS COD pH 2
pH 6~9 pH 2

C.

 SBR PAC PAM
SBR

D.

75%~80%

9.3.2.2

A.

COD

Ca(OH)₂

$3\text{HPO}_4^{2-} + 5\text{Ca}^{2+} + 4\text{OH}^- \rightarrow 5(\text{OH})(\text{PO}_4)_3 + 2\text{O}$

$\text{Ni}^{2+} + 2\text{OH}^- \rightarrow 2$

pH pH

Ni pH Zn

99%

B.

C.

COD SS

D.

SBR

SBR

SBR

E.

0.5mg/L

SBR

PAC PAM

90%

0.5mg/L

3

3-10 3-11

9-3

9-3

			(m ³ /d)	mg/L						
				SS	COD		Zn	Ni		BOD ₅
1			150.94	120.17	251.96		32.18	29.76	190.47	
				19	123		0.32	0.30	1.90	
	PH	1		84%	51%		99%	99%	99%	

9-3

			(m ³ /d)	mg/L						
				SS	COD		Zn	Ni		BOD ₅
2			57.74	1095	8411	374.44				
				164	2103	56.17				
				85%	75%	85%				
				212	1476	57.01				
4			341.76	42	369					

PH 2

H.

COD

9.4

9.4.1

1

2

9-2

9-4

		+HDPE -10cm/s GB18599-2001
		GB15562.2-1995 GB18597-2001 +HDPE -10cm/s
		+ -10cm/s S8
		+HDPE 1.0×10 ⁻¹⁰ cm/s
		+ -10cm/s
		-7cm/s

9.4.2

1

9-2

9-5

9-5

1				pH	1 /	

9.4.3

9.4.4

9.5

75~105dB(A)

GB12348-2008 3

9.6

9.6.1

3-9 3-10

9.6.2

9.6.3

		1	120m ²
240	50L	0.09m ²	3
	7.2m ²	2.23t	
	7		

0.5m

10^{-10} cm/s

14

44.6t/

GB18597-2001

HJ2025 -2012

9-6

9-6

1				120m ²		100t	14

9.7

9-7

9.8

9-7

	CO ₂	+15m	1	m ³ /h	1	40	
		15m	3000	m ³ /h	1	2	2 2
		+			30	60	
		m ³ /h	+	+40m	38.5	1	4500
		+27m	7.7	m ³ /h	3	280	2
		+27m	1.2	m ³ /h	4	20	2
						150	
		+27m	2	m ³ /h	1	5	
						30	2
						5087	
		40m ³			1	2.5	
		50m ³			1	2.5	
		15m ³ /h	pH	2	2	pH	
		10m ³ /h	pH		1	30	
		30m ³ /h	pH		1	100	GB8978-1996 4
		30m ³ /h	SBR		1	110	
					4	40	
					3	90	

9-7

			1	30	
			1	460	
			1	60	
			1	10	
				1005	
				35	3
				10	
				70	
				35	
	6			/	
				150	
				200	
			3	6	
				/	
				/	
				/	
		120m ²	1	10	
		125000m ²		28.44	
				6486.44	

10

10.1

10.1.1

2011

2013

2011

2013

2011

2013

10.1.2

2009

2009

2009

10.1.3

[2017]53

10

10.1.4

2017 1055

10.1.5

2012-2020

[2012]22

2012 6 28

2012-2020

2015

50

2020

200

500

2012-2020

2012-2020

10.1.6

[2014]35

2014 7 21

[2014]35

30%

[2014]35

10.1.7

3. VOCs

2

VOCs

90%

80%

B1 B2

B1 B2

98%

TNV

98%

90%

10.1.8

[2018]83

VOCs

GB16297-1996 2 VOCs

2

GB13271-2014 3

[2018]83

10.1.9

[2016]114

10-1

10-1

1			
2			
3			
4	80%	87.38%	5%

10-1

11		300m	
----	--	------	--

12

10.2.2

10-1

2007 574

2007 9 8

10-2

10-2

1	1		
2	2		
3	3	2007	

	<p>2010</p> <p>50%</p>	<p>2007</p>	<p>70%</p>	
4	4			

11

11.1

COD SO₂ NO_x VOCs

11.2

11-1

11-1

t/a

	m ³ /a	181949.8	0	181949.8
		109.57	106.58	2.99
SO ₂		2.32	0	2.32
NO _x		10.84	0	10.84
VOCs		377.21	368.90	8.31

VOCs

136.322t/a

11.4

11.4.1

73512.93m³/a

14457.5m³/a

(135925m³/a)

223895m³/a COD

150mg/L 0.75mg/L 0.05mg/L COD

24.64t/a

0.102t/a 0.007 t/a

11.5

100%

13

13.1

13.1.1

13.1.2

8
2

3

2

13-1

13-1

	1 2 3 4
	1 2 3 4 5 6
	ISO14001

13.1.3

1

2

3

4

5

6

7

8

13.1.4

13.1.4.1

13-2

2-1

13-3

13-2

		m ²	
		146400	
		81000	
		136000	
		13000	
		2268	
		30095.46	
		1000	
	3	79680	
		8050	
		3600	

13-2

16		t/a	139	PAM PAC
17		m ³ /a	271	
18		m ³ /a	150	
19		m ³ /a	115	
20		m ³ /a	64	
21		m ³ /a	400	
22		m ³ /a	800	
23		t/a	80	
24		/	10	
25		/	10	
26		/	10	
27		/	10	
28		/a	10	
29		/a	10	

13.1.4.2

13-4

13-4

mg/m

	mg/m ³ mg/L	t/a	mg/m ³ mg/L
	7.12	0.78	20
	0.07	0.007	0.5
	0.11	0.012	5.0
	0.1	0.011	1.0
	0.93	0.102	15
BOD ₅	5.12	0.56	160
	8,21	0.12	100

13.1.4.3



9-7

13.1.4.4

GB15562.1.1995

13-5

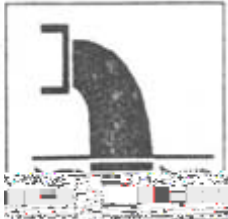
13-5

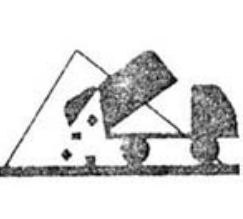
1				
2				
3				

13.2

13.2.1

HJ 819-2017

14-6

13.2.2

HJ 819-2017

13-6

13-6

		CO ₂		/	GB16297-1996 2
			VOCs SO ₂ NO _x	/	
			VOCs SO ₂ NO _x	/	524-2014 DB12/ 2
				/	
					GB8978-1996 1
			SS pH COD	/ COD	GB8978-1996 4
			pH	1 /	GB/T14848-2017
			Leq	1 /	(GB12348-2008)3 4

13.2.3

14

14.1

128.4hm²(1926)

506111

10

14.2

2011

2013

2009

2012-2020

2017 1055

[2016]114

14.3

14.4

14.5

14.5.1

			1		90%
	1	15m			
	B1	B2			98%
+			92%		TNV
		98%		4	
	80%		TNV		
35m					
TNV			98%	1	20m
					80%
15m					
	1	15m			
	GB16297-1996	2			
				DB12/ 524-2014	2
	GB13271-2014	3			

14.5.2

	GB 8978-1996	1			
					GB 8978-1996
4					

14.5.3

GB12348-2008 3 4

14.5.4

120m²

14.6

SO ₂	NO _x	2.32t/a	10.84t/a	VOCs
				8.31 t/a
COD		24.64t/a	0.102t/a	

GB 18918-2002 A

14.7

14.7.1

		2017	SO ₂	CO		
	PM ₁₀				NO ₂	O ₃
PM _{2.5}						

2018 10

0.395~0.538mg/m³

0.198~0.269

14.7.2

LAS

GB3838-2002

14.7.3

GB/T14848-2017

14.7.4

GB3096-2008 3 4a

14.7.5

GB36600-2018

14.8

14.8.1

SO₂ NO₂

SO₂ NO₂

GB3095-2012

HJ2.2-2018

D.1

0.2mg/m³

2.0mg/m³

GB16197-1996

DB12/ 524-2014 5

300m

1

GB/T 18075.1-2012

